

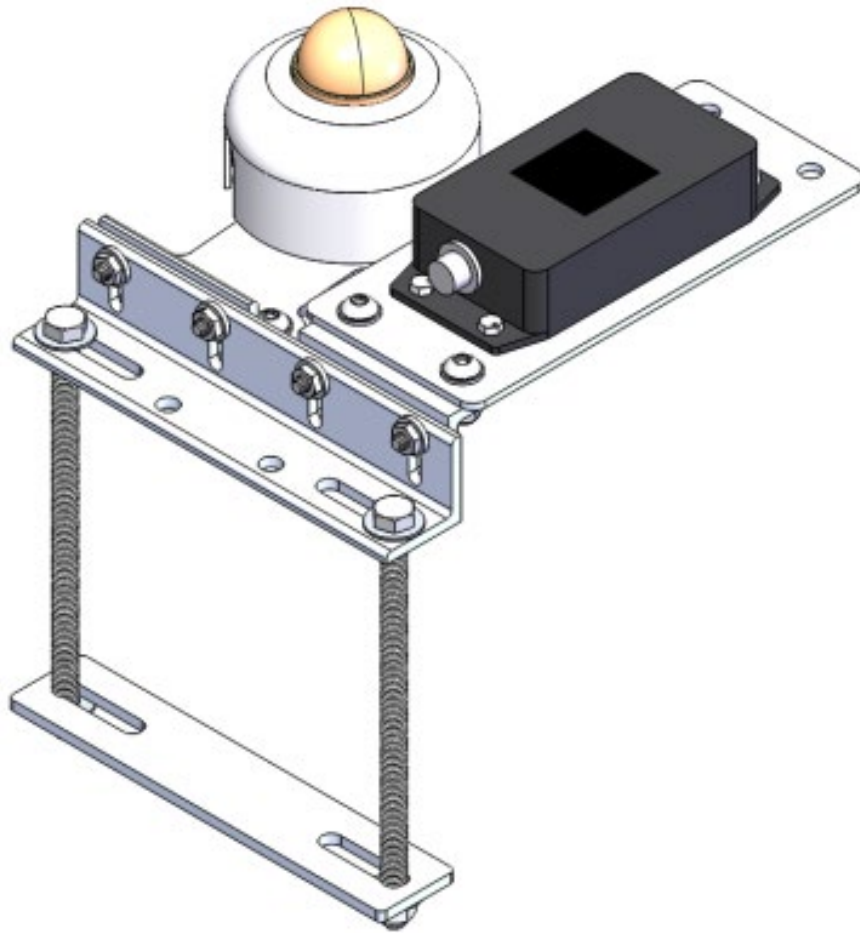

Pyranometer Mount #17830 | Dual POA Reference Cell and Pyranometer Mount

Introduction

Kit #17830 was designed to mount a Reference Cell and Pyranometer using a Reference Cell Mounting Plate #15756, Universal Mounting Plate #15498, and a #17831 adjustable bracket to a square torque tube.





Pyranometer Mount #17830 | Dual POA Reference Cell and Pyranometer Mount

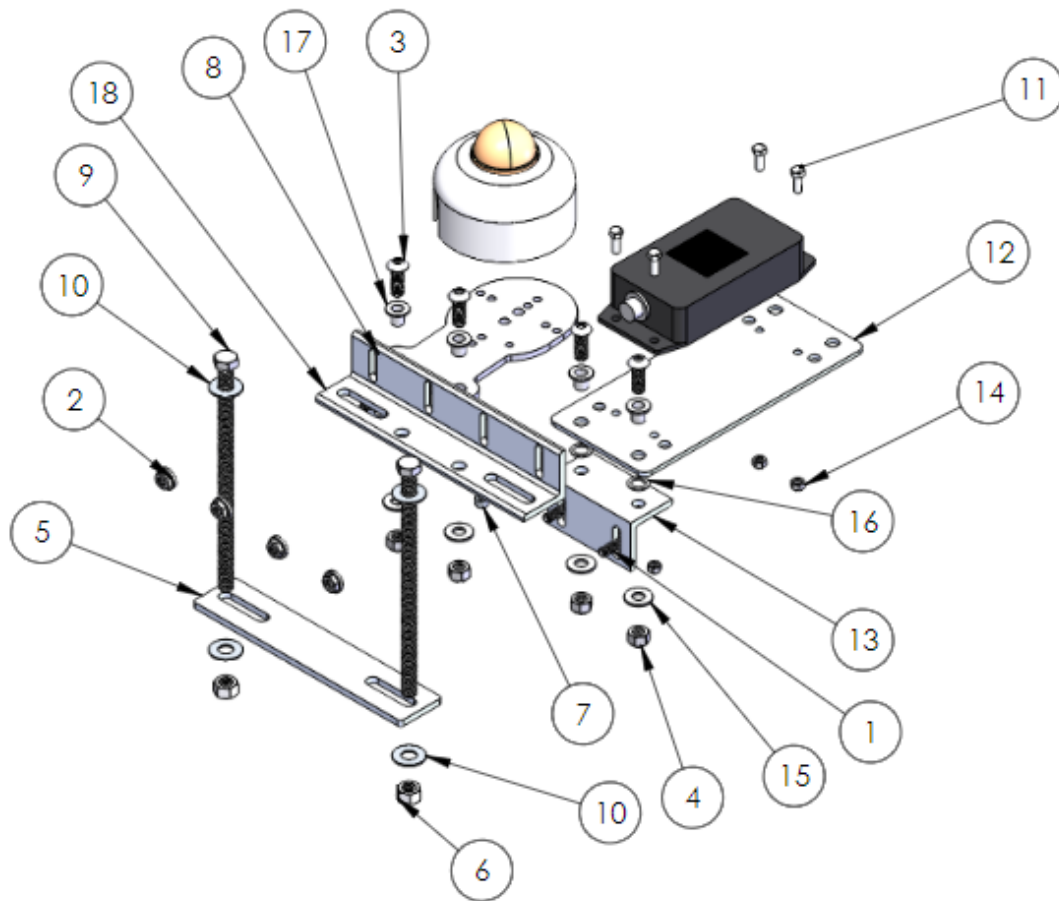

#17830: Parts/BOM

NRG Part Number	Part Description	Part Specification Notes	Qty	Diagram Key
10194	Screw	Screw, Cap, M5 x .8mm, 14mm Length	5	11
12022	Button Head Screw	1/4-20 thread 0.75" length Stainless	5	1
12095	Washer	Washer, .375 Inch x .875 OD, SS	4	10
14397	Pyranometer Mounting Screws	M5 x 0.8 10mm length Stainless	3	7
14975	Nut	Nut, M5, Stainless, Nylock	5	14
14979	Nyloc Nut	5/16-18 thread Stainless	5	4
14980	Button Head Screw	5/16-18 thread 0.875" length Stainless	5	3



Pyranometer Mount #17830 | Dual POA Reference Cell and Pyranometer Mount

15498	Mounting Plate	Aluminum 3/16" thickness	1	8
15756	Reference Cell Mounting Plate	Plate, Reference Cell, Boom Mount	1	12
15821	Angle Bracket	Pre-drilled angled aluminum	1	1
15869	Serrated Flange Locknut	1/4-20 Threaded Stainless	5	2
16091	Bottom Plate	Bottom Plate, Square Torque Tube POA, Universal	1	5
16101	Nut	Nut, .375-16, Hex, 18-8 SS	2	6
17245	Hex Head Screw	.375-16, Hex Head Screw, 7in, fully threaded, 18-8 SS	2	9
17831	Adjustable bracket	Adjustable POA Bracket, Short	2	13
18249	Nylon washers	Washer, Nylon, .34 ID	4	15
18250	Nylon washers	Washer, Nylon, .375 ID	4	16
18251	Nylon sleeve washer	Washer, Sleeve, Nylon, .3125 ID	4	17
18519	POA Bracket	POA Bracket, 4 Slots	1	18

Tools

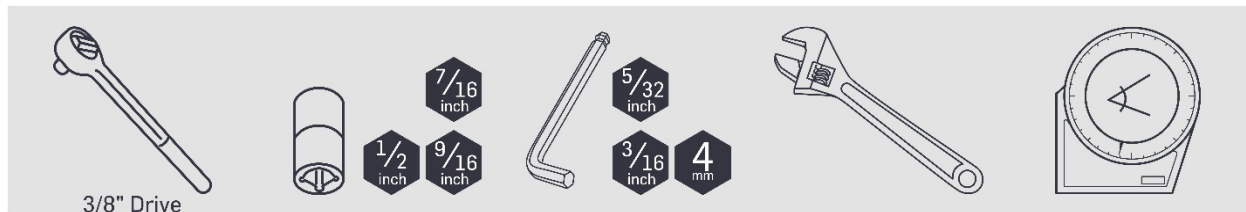



Pyranometer Mount #17830 | Dual POA Reference Cell and Pyranometer Mount

INSTALLATION PROCEDURE

1. Assemble the #18519 POA Bracket and the #16091 Bottom Plate using the long #17831 Hex Head Screws, the #12095 washers, and the #16101 nuts as shown below. Slide onto the torque tube with the slots facing away from the panels, and tighten the nuts enough to hold the assembled brackets securely before final adjustments.

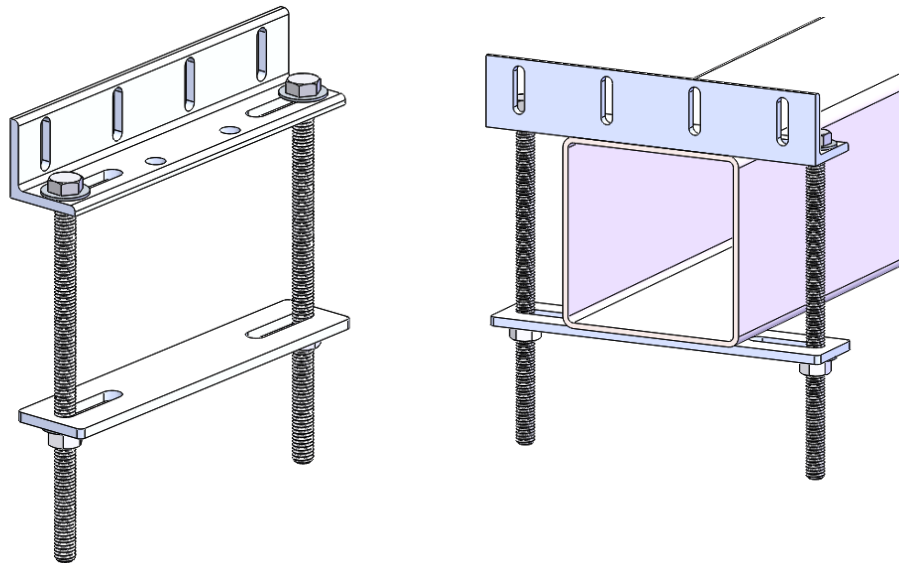

2. Attach the #17831 Adjustable Brackets with the #10194 screws, #14979 Nyloc Nuts, and #18249 Nylon Washers oriented as shown below. Leave slightly loose for final adjustment at the end.

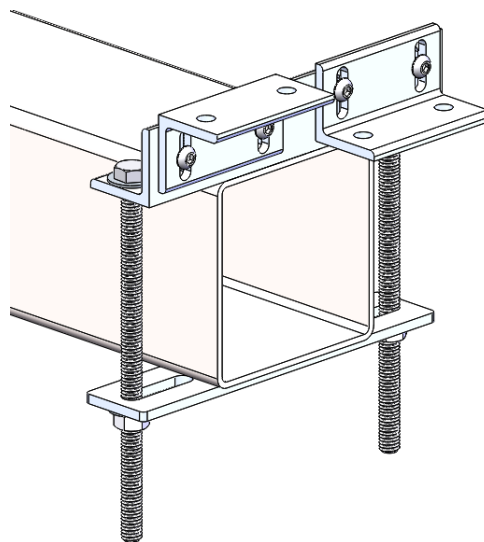



Pyranometer Mount #17830 | Dual POA Reference Cell and Pyranometer Mount

3. Insert the screws into the nylon sleeve washers #18251 and then through the holes in the Universal Mounting Plate #15498 and the Reference Cell Mounting Plate #15756. Add nylon washers #18250 to the ends of the screws, and insert the screws through the holes in the angle bracket #18519. Add nylon washers #18249 to the ends of the screws before adding the nuts as shown below. Nylon washers are represented below in blue.

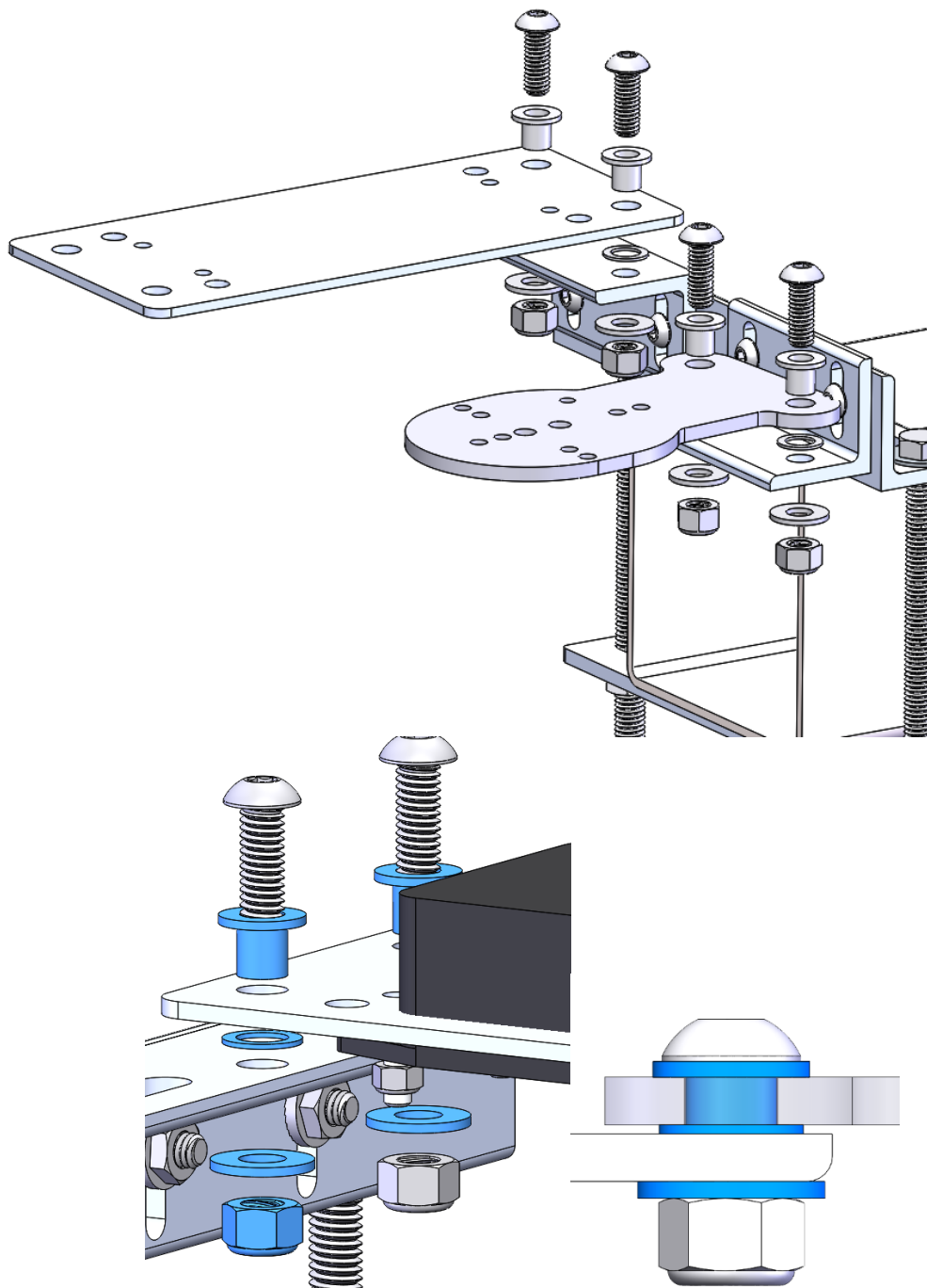



Pyranometer Mount #17830 | Dual POA Reference Cell and Pyranometer Mount

4. Ideally the cable should exit towards the nearest pole for both sensors. Install the Reference Cell to the plate using the #10194 screws and #14975 nuts. Remove the pyranometer feet. The pyranometer mounts directly to the bracket. Attach the pyranometer to the Universal Mounting Plate #15498 using the M5 stainless hardware.



Install the sensor with the cable exiting towards the nearest pole.

Apply a small amount of anti-seize to the bolt threads.

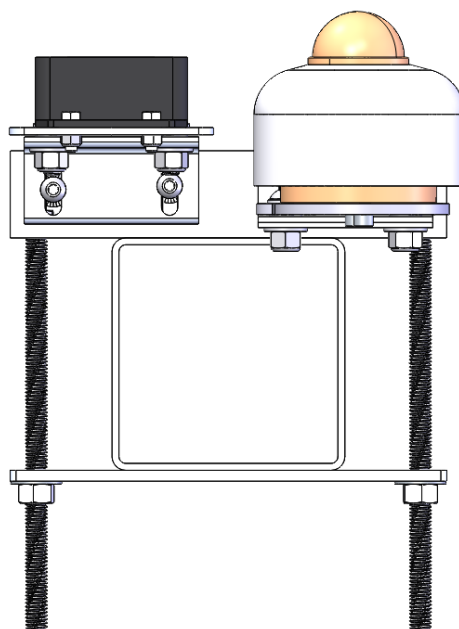
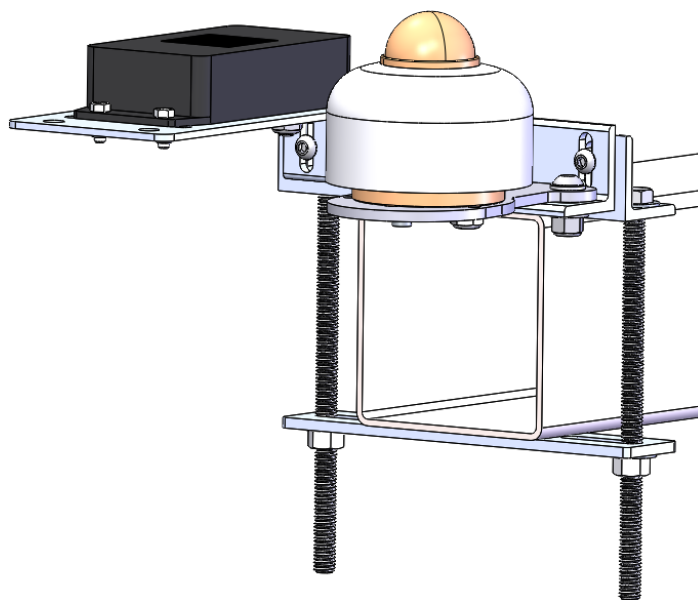



Pyranometer Mount #17830 | Dual POA Reference Cell and Pyranometer Mount

5. Check that the pyranometer and reference cell are at the correct angle along both axes. Adjust if necessary.

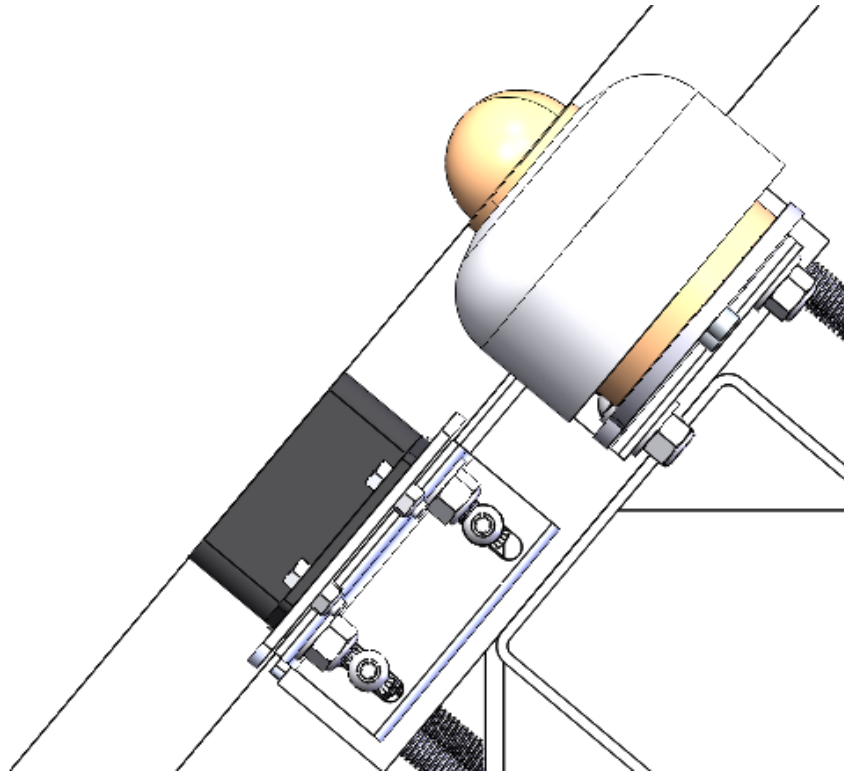

It is critical that the pyranometer be in plane with the PV panels, at the same angle/level.



If possible, level the array table and then install the sensor, taking care that the pyranometer mount is at the same level as the PV panels.



Pyranometer Mount #17830 | Dual POA Reference Cell and Pyranometer Mount

Additional Configurations

Pyranometer Mount #15845 can be assembled in several ways for more adjustability. RPOA (not shown) is also possible, as Universal Mounting Bracket #15498 is identical on both faces.



When used for RPOA, the white sun shield should be removed and the sensor cable should exit along the array, typically north or south.

