



NRGSystems®

FLARE

Solar Resource Measurement

NRG Flare is a portfolio of solar solutions that provide the data you need to successfully plan and operate your utility-scale photovoltaic projects. Encompassing everything from standardized hardware to data management tools and installation and maintenance support, our turnkey systems ensure reliable and repeatable performance, every time.

Flare Systems

NRG offers two complete measurement solutions – the Flare SRA System for the early prospecting and formal pre-construction resource assessment of utility-scale PV projects, and the Flare SRM System (Tower and Array options) for performance monitoring per IEC 61724-1:2017.

Solar Resource Assessment

DEVELOPMENT PHASE

NRG Systems' Flare SRA System systematically collects "ground truth" meteorological data at a prospective solar energy production site. Our complete and integrated measurement solution captures all relevant conditions so users can lower the uncertainty of AEP estimates associated with utility-scale photovoltaic projects.

Solar Resource Monitoring

OPERATIONAL PHASE

NRG Systems' Flare SRM System helps operators monitor and optimize the output from their utility-scale PV plant. Whether the project is tracking or fixed, mono- or bifacial, we help users detect inefficiencies at the module, string, and system-wide levels so they can launch real-time maintenance and build long-term, preventative maintenance and cleaning programs.

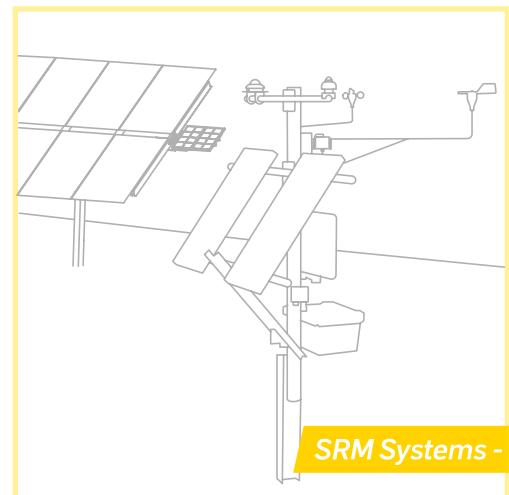
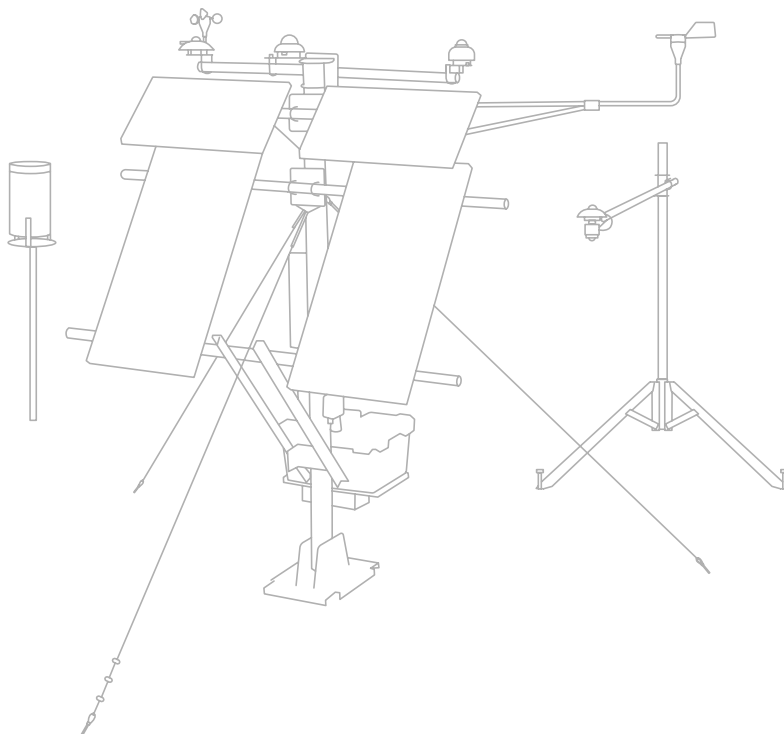

SRM Systems - Tower

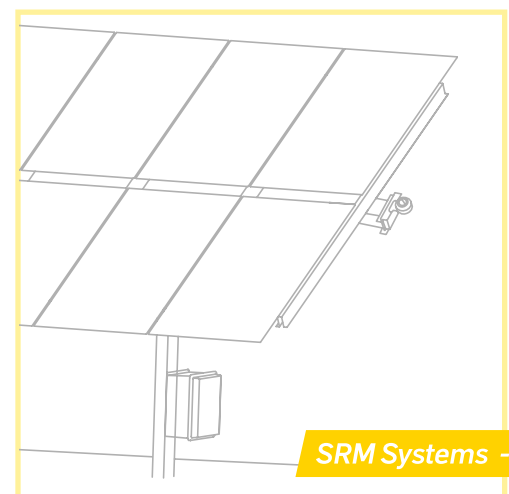

SRM Systems - Array

How Flare Systems Work for You

NRG Systems' Flare Solar Resource Measurement solutions apply to pre-construction assessment through post-construction operational monitoring and are designed to transition seamlessly between the two.



Solar Resource Measurement Systems

System Anatomy

1



Data Logging

NRG LOGR Family and SymphoniePRO data loggers

2

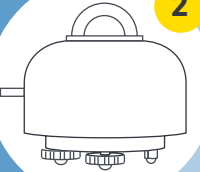

Solar Irradiance

Industry-leading irradiance sensors

3

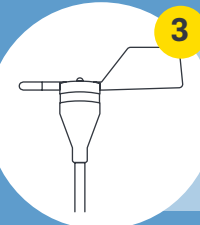

Meteorological Sensors

Highly reliable, discrete sensors

4

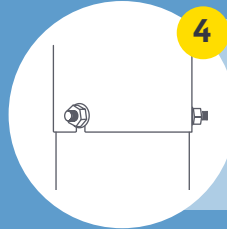

Tubular Tower

Quick to ship, easy to install

5

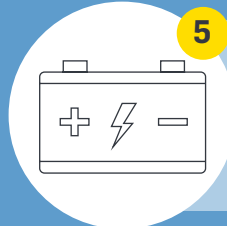

Auxiliary Power

Autonomous power in any setting

6

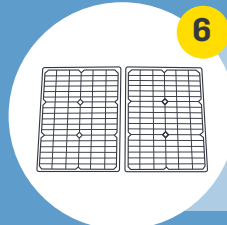

Soiling Measurement

35 W or full-size PV options

Turnkey Installation Services

Support for all stages of project development

NRG Cloud

Retrieve, store & share data, from anywhere



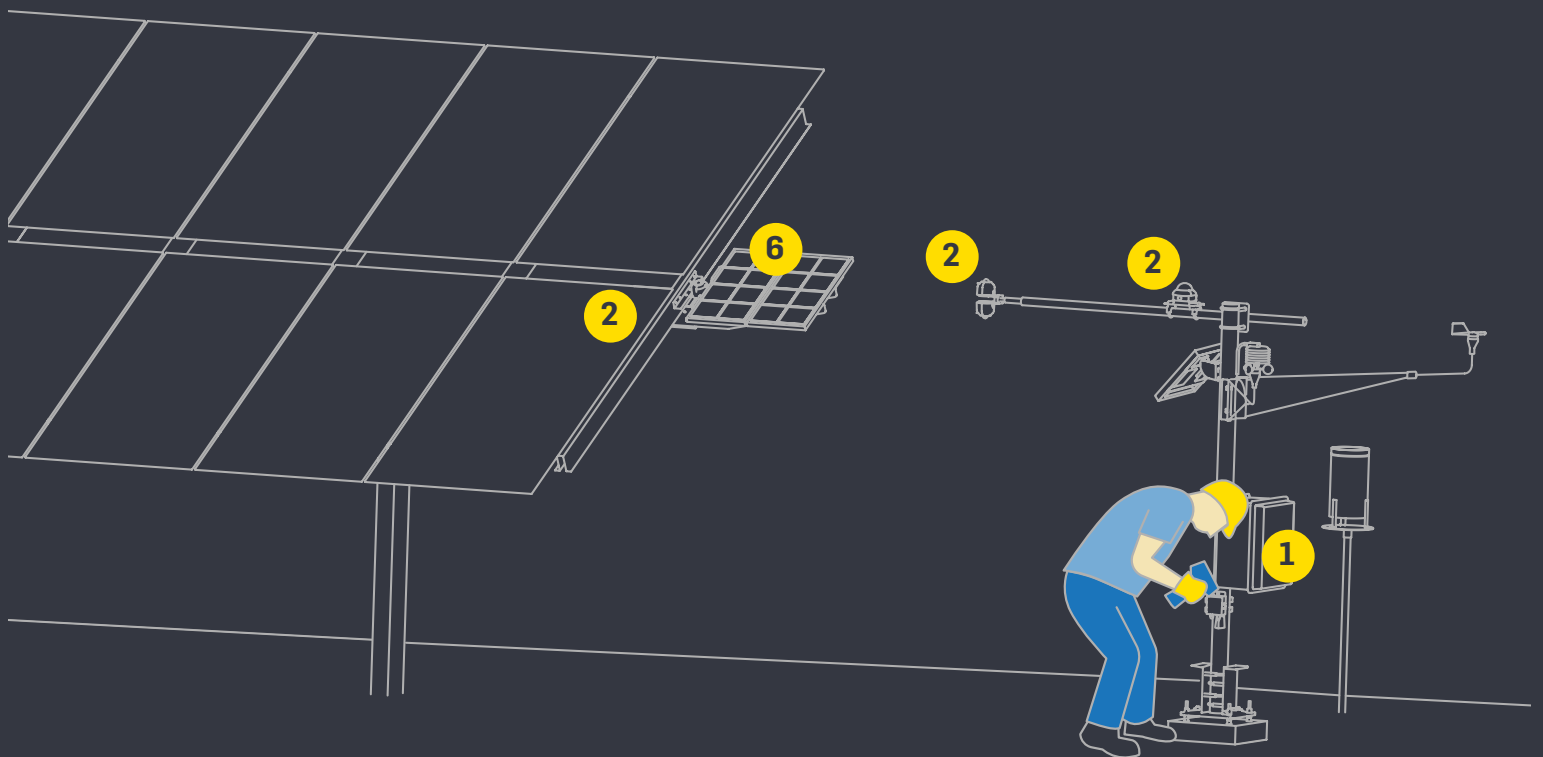
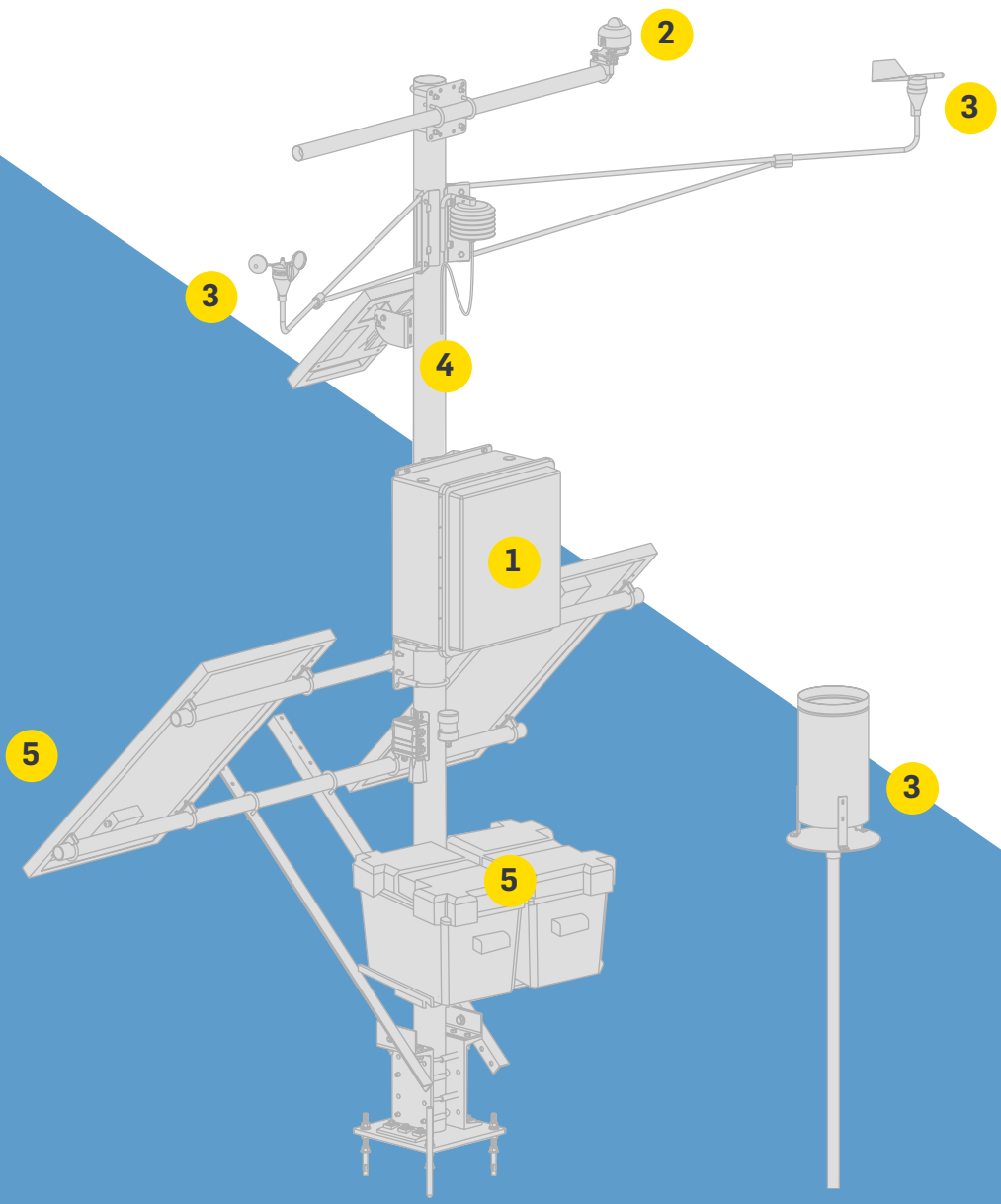

Solar Solutions | Component Details

Data Logging

NRG LOGR FAMILY AND SYMPHONIEPRO DATA LOGGERS

- High-resolution, high-accuracy measurements
- Long-term data storage
- Supports wide range of sensor types (analog, digital, serial)
- Calculated channels for additional solar information (solar position, direct normal irradiance (DNI), albedo)
- Easily configurable – no programming required
- Modular accessories for global communications & autonomous power support (Modbus TCP, Cellular, Satellite)

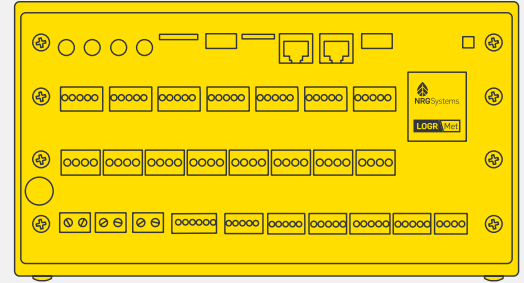
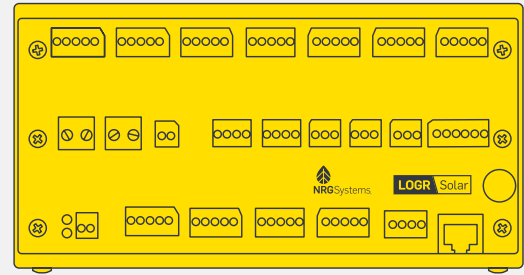

Solar Irradiance

ACCURATELY CAPTURE THE PRIMARY MEASUREMENT OF INTEREST IN A SOLAR RESOURCE CAMPAIGN

- All irradiance components (Global, Diffuse, & Direct) supported
- Class A, B, or C pyranometer options
- System compatibility with all industry-leading sensor brands
- Output options: analog vs. serial ("smart") sensors
- Thermopile pyranometer or PV reference cell
- Mounting flexibility for horizontal vs. plane-of-array irradiance capture
- Pyranometer heating & ventilation options

FEATURED SENSORS

Economical class A sensor with various output options



Innovative class A "smart" sensor with internal heat & ventilation



Captures all three irradiance components (GHI, DHI, DNI (calculated)) with low power & no moving parts

PV Module Temperature

ACHIEVE IEC CLASS A MEASUREMENTS USING OUR HIGH-ACCURACY 0.2 C INTERCHANGEABLE 10K NTC THERMISTOR SENSOR

- Our 0.2 C interchangeable 10K NTC Thermistor sensor ensures Class A measurements per IEC-61724-1:2017
- 4-wire configuration ensures accurate measurement regardless of cable length and enables flexible positioning on array
- Easy and repeatable installation and long-term performance via specially designed adhesive system

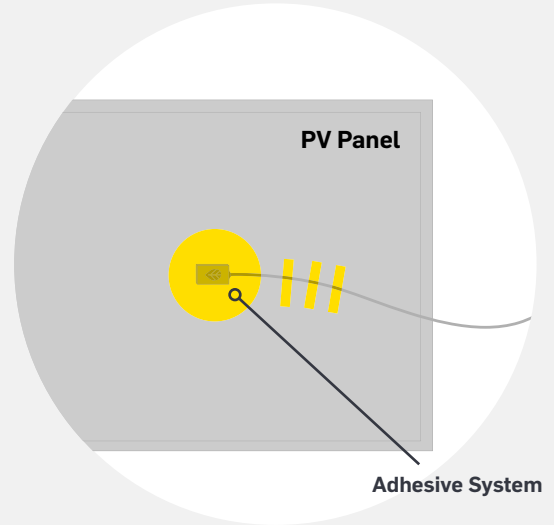

Meteorological Sensors

COST-EFFECTIVE AND INDIVIDUALLY REPLACEABLE MET SENSORS CAPTURE:

- Wind Speed
- Wind Direction
- Ambient Temperature
- Relative Humidity
- Barometric Pressure
- Precipitation

Tower & Mounting

FLEXIBLE SOLUTIONS FOR ALL SETTINGS

- Tubular Tower height options:
 - 2.2 m (7 ft)
 - 3 m (10 ft)
- Temporary (guyed) or Permanent (pad or pile-mount) base designs

Auxiliary Remote/Uninterruptable Power Supplies

SCALABLE, MODULAR POWER SUPPLY, SIZED BY PROJECT DEPENDING ON:

- Sensor configuration
- Project location
- Autonomy requirements

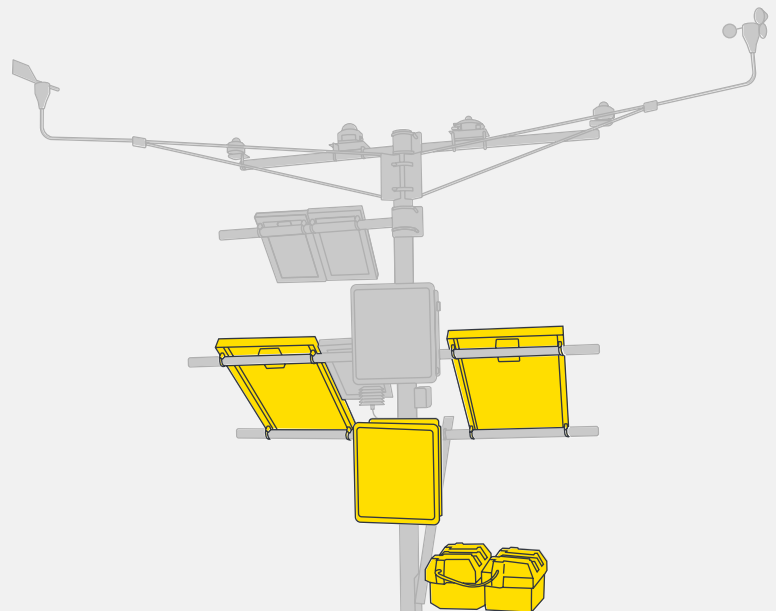

Albedo Measurement Kit

- Unobstructed horizontal albedo measurements for bifacial PV modules
- Supports full range of pyranometers
- Matte black finish eliminates shading/reflections
- Special mounting fixture supports fixed or tracking installations

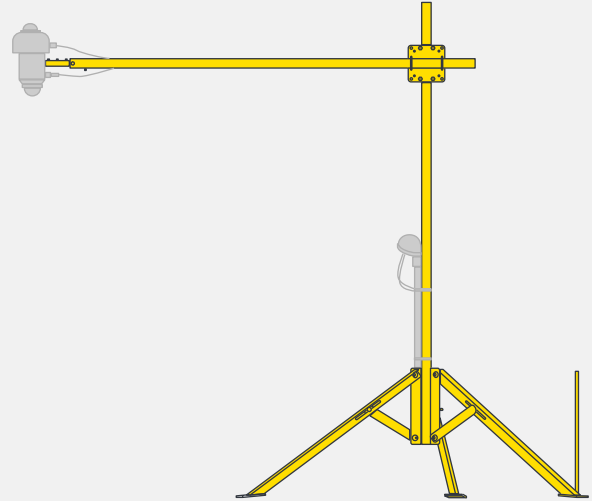

Soiling Measurement Kit

- 35 W or full-size PV module options
- Fixed (tower) or tracking (array) mounting
- Clean and reference PV modules tested and paired at NRG
- I_{sc} and PV (back-of-module) temperature measurements provided

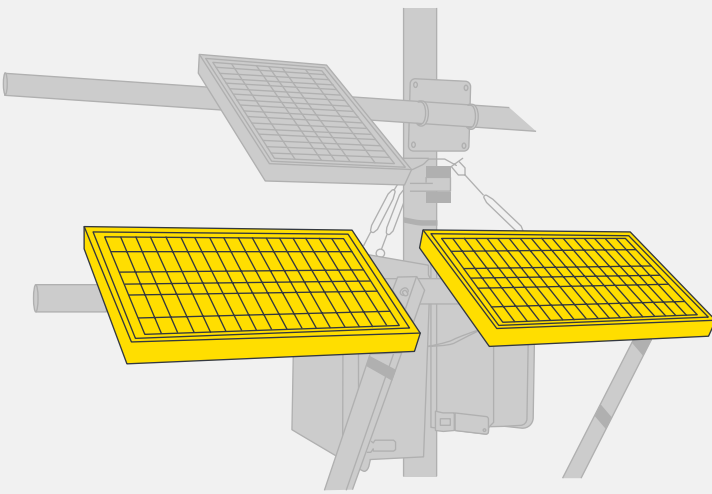

Services

FOR TURNKEY MEASUREMENTS, OUR SERVICES INCLUDE:

- NRG Cloud web application
- Pre-configuration and engineering documentation
- Equipment installation and maintenance
- Data services to streamline data delivery, processing, site monitoring, and data quality assurance



For more information:

NRG Sales

+1 802.482.2255

solar@nrgsystems.com

nrgsystems.com

ISO 9001: 2015 Certified

ISO 14001: 2015 Self-Certified

