

NRG Systems Classic 20H Turbine Control Vane Part #5347



110 Riggs Road • Hinesburg • VT 05461 USA • TEL (802) 482-2255 • FAX (802) 482-2272 • EMAIL sales@nrgsystems.com • www.nrgsystems.com

Specifications are subject to change without notice.

© NRG Systems, Inc.
PO Box 509
Hinesburg VT 05461
Tel: 802-482-2255
Fax: 802-482-2272
e-mail: sales@nrgsystems.com

Contents

Customer Support	4
Introduction.....	5
Using This Manual	5
20H Operation and Considerations.....	6
Output Circuit Operation.....	6
ESD and Circuit Protection	6
Transport and Handling	7
Installation and Technical Drawings.....	8
Mounting Mast and Sensor Orientation.....	8
Connections	8
Cable to Controller	8
Technical Drawing	9
Technical Specifications	11
Appendix A: Grounding and Bonding NRG Systems Classic Turbine Control sensors for lightning and over-voltage protection	12
Introduction	12
Recommended Practices	12
References.....	13
Appendix B: Warranty & Repair	14
Two Year Limited Warranty.....	14
INTERNATIONAL CUSTOMERS	15

Customer Support

NRG Systems offers a variety of support options to help you get the most from your NRG product. If you have questions about your NRG product, first look in the printed product documentation, the Knowledge Base and the Technical Forum contained in the Tech Support section of NRG's web site. If you cannot find the answer, contact your salesperson or NRG Systems Technical Support for assistance using the information below. Customer support is available 8:30 AM to 5:00 PM EST, Monday through Friday.

NRG Systems, Inc.
110 Riggs Road
Hinesburg, Vermont
05461 U.S.A.

Telephone: 802-482-2255
Toll Free (USA only): 800-448-WIND (800-448-9463)
FAX: 802-482-2272
Email: support@nrgsystems.com

When you call or email, you should have the appropriate product documentation at hand and be prepared to give the following information:

- Customer name
- Who purchased equipment
- Item number or description
- Serial number
- When equipment was purchased
- Where equipment is installed - terrain conditions
- Description of the problem with some detail
- What events took place leading up to the problem
- What you have tried while attempting to solve the problem

NRG Systems maintains an extensive website which includes an in-depth technical support area for NRG customers. If you need assistance at times other than our regular business hours, we suggest visiting our website, **www.nrgsystems.com**.

All instruments, sensors, software and towers manufactured by NRG Systems are designed to be reliable and easy to use. We welcome your comments and appreciate your help in making NRG products the best available.

Introduction

The NRG Systems Classic 20H Turbine Control Vane is a wind direction vane which provides 4 to 20 mA output signal. The NRG 20H is designed primarily for wind turbine control. The sensor is mounted to the turbine nacelle and provides a relative wind direction signal to control active yaw of the wind turbine.

The 20H is rugged enough to tolerate the environment on a wind turbine nacelle, yet its relatively low moment of inertia permits it to respond rapidly to gusts and lulls. It is built with corrosion resistant materials and finishes and is sealed against wind-driven rain and dust.

Together with the NRG Systems Classic 40H Turbine Control Anemometer, the NRG Systems Classic turbine control sensors provide a complete set of wind sensors. Although primarily intended for wind turbine control applications, these sensors are also well suited for other control or environmental monitoring applications.

Using This Manual

Read this manual completely before installing and operating the 20H. Follow all instructions and recommendations closely.

This document and the sensor may use the following symbols:



Earth (Ground)



Chassis Ground



AC Voltage



AC or DC Voltage



DC Voltage



Warning

This typeface within the body of the manual is used for general descriptions and instructions to the user.

This typeface is used to warn users of a potential danger, either to themselves or to the sensor.

20H Operation and Considerations

Output Circuit Operation

The 20H provides an industry standard 4 to 20 mA output signal sourced by the sensor. The output range of 4 to 20 mA corresponds to 0 to 360 degrees.

For yaw control, the 20H vane should be mounted so that an indicated direction of 180 degrees corresponds to a turbine direction oriented directly into the wind. In this configuration, the sensor output signal is 12 mA when the turbine is aligned with the wind, and the deadband at the transition from 4 mA output to 20 mA output is opposite the normal control direction.

Under normal operation, the current output varies from 4 to 20 mA. A signal outside this range indicates a fault condition. The most likely causes would be a loss of power, a wiring problem, or a failed sensor.

Mounting

The 20H is designed to fit over a mounting mast with an outside diameter of 13 mm (0.5 inch). The mounting mast must be hollow and be open at the bottom to allow any condensed moisture or wind-driven rain to drain from the sensor.

When used in wind turbine control applications, the sensor should be oriented with its mid-range oriented into the wind to provide a continuous and linear output around the desired wind direction. Mount the sensor with its North orientation mark pointing away from the rotor. The sensor has a through-hole for a cotter pin which is oriented across the sensor (East to West), so the mounting mast should have the through-hole oriented perpendicular to the rotor center line.

Mount the sensor, and place the cotter pin in the through hole. This allows a small amount of adjustment to orient the sensor exactly as desired. Tighten the set screw to complete the installation.

The cable to the sensor is routed next to the mounting mast at the sensor base, and the cable can be routed into the mast or alongside the mast as desired. Refer to the wiring diagram to connect the wiring to the sensor. Coating the completed connections with a small amount of electrical silicone grease or petroleum jelly is recommended to prevent corrosion of the wiring. Always use the included terminal boot to protect the sensor connections. The boot also provides a smooth aerodynamic fairing for the base of the sensor.

ESD and Circuit Protection

Lightning protection, electrostatic discharge protection and circuit overvoltage protection are critical for a reliable wind turbine control design. The 20H sensor has been designed to withstand most common wiring errors and electrostatic discharges.

IEC standard 62305-1:2011 provides guidance and common terminology for lightning protection system design. The standard defines Lightning Protection Zones (LPZ) based on their exposure, and whether the zone is protected from lightning energy by shielding, isolation, and over-voltage protection.

A properly designed lightning protection system for the wind turbine is necessary to protect the 20H direction sensor from direct lightning strikes. Even with properly designed lightning protection, since the sensors must be outside the nacelle, in the event of a lightning strike they are subjected to the secondary Lightning Electro-Magnetic Pulse (LEMP). The standard classifies this exposure as LPZ 0_B.

Circuit protection between the sensors and the controller must be provided to protect the controller in LPZ1 or LPZ2 as

required. Refer to Appendix A for more specific information on circuit protection, shielding, bonding, and grounding.

Transport and Handling

This sensor is a precision instrument. Please use care in its handling to protect the bearings and shaft.

Installation and Technical Drawings

Mounting Mast and Sensor Orientation

Refer to the “Installation Simulation” drawings for details on mounting the sensor and the recommended mast design. In wind turbine control applications, orient the cross-hole in the top of the mounting mast perpendicular to the turbine nacelle centerline. Mount the sensor to the mast with the North index mark away from the wind. This orients the mid-range output in the operating control range.

Connections

Refer to the “Installation Simulation” drawings below for details on wiring the 20H sensor to your control system.

Cable to Controller

Route the sensor cable into the nacelle and to its connection point. It may be helpful to label the end of each wire before pulling the cable to its connection point. Following the color code appropriate for your cabling, connect the sensor wires and shield wire to the turbine controller.

Sensor Common	Common ground for sensor power and signal. The sensor’s internal metal parts are also grounded to the common ground terminal.
Sensor Power	power supply to the sensor
Sensor Signal	output signal current from the sensor to the controller or logger
Shield	Cables should be shielded. Cable shields may be bonded to the mounting booms in coordination with the overall lightning protection of the system.

Technical Drawing

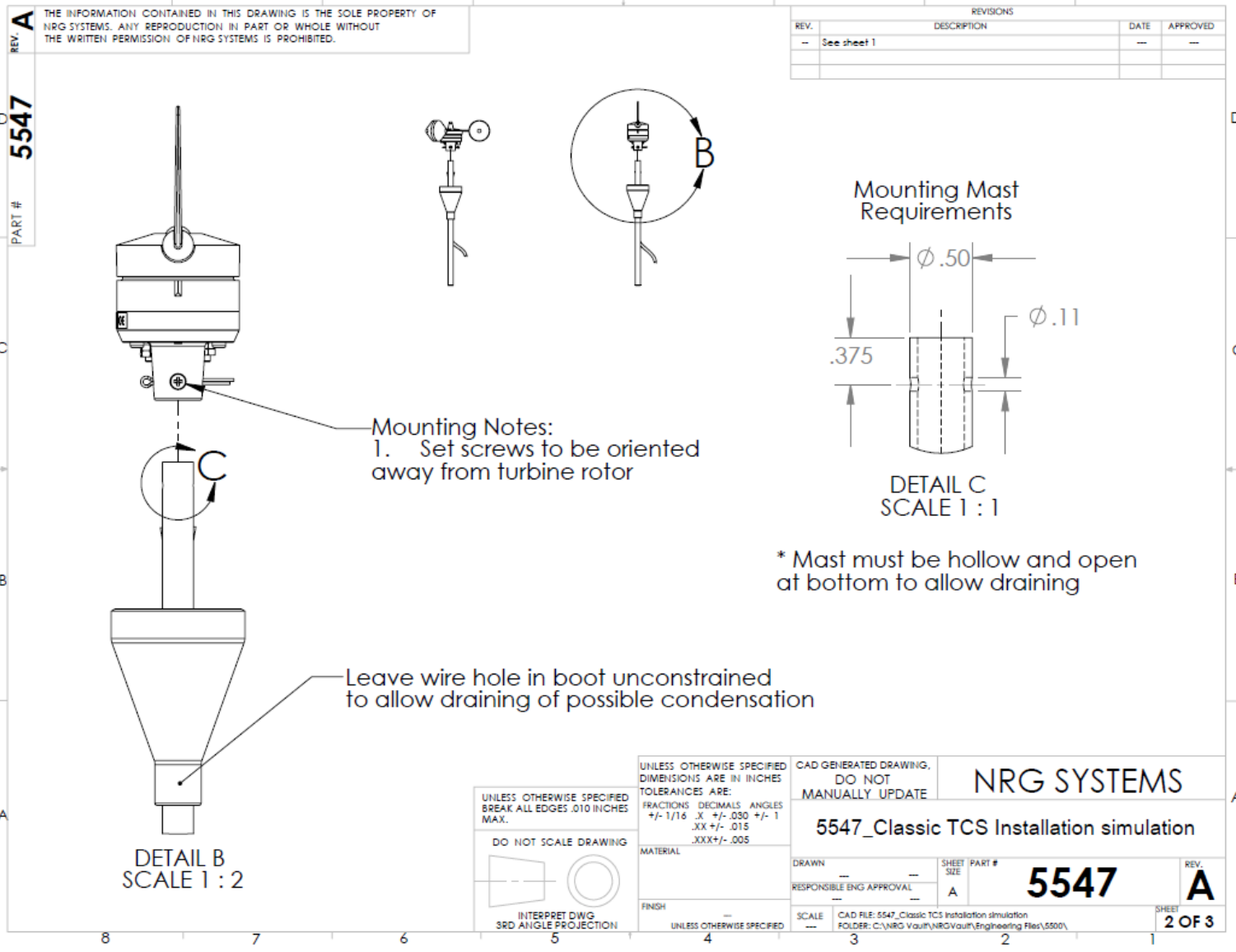

REV. **A** THE INFORMATION CONTAINED IN THIS DRAWING IS THE SOLE PROPERTY OF NRG SYSTEMS. ANY REPRODUCTION IN PART OR WHOLE WITHOUT THE WRITTEN PERMISSION OF NRG SYSTEMS IS PROHIBITED.

PART # **5547**

REVISIONS			
REV.	DESCRIPTION	DATE	APPROVED
--	See sheet 1	--	--

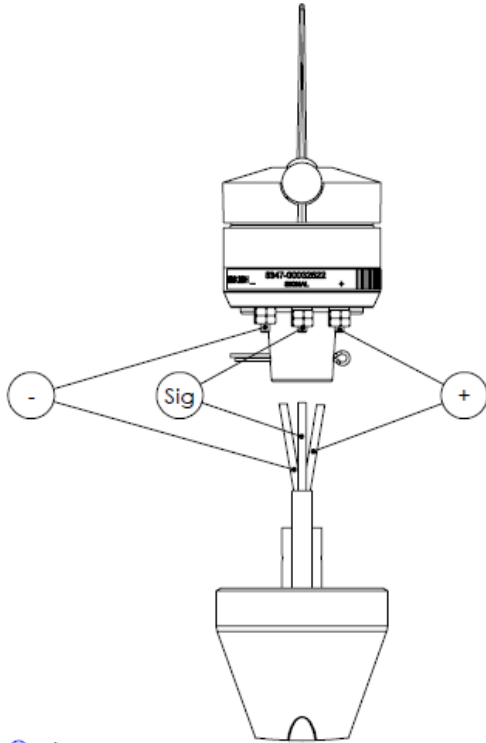
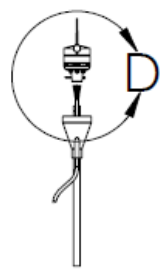

DETAIL D
SCALE 1 : 2

- Wiring Notes:**
1. Sensor Cable, 3 conductor w/shield
 2. Tighten cable connection nut to 8lb*in (10kgf*cm)
 3. Cable shield connected to earthing, lightning protection as required
 4. Overvoltage protection to IEC 62305-1: 2011 is recommended
 5. See instructions

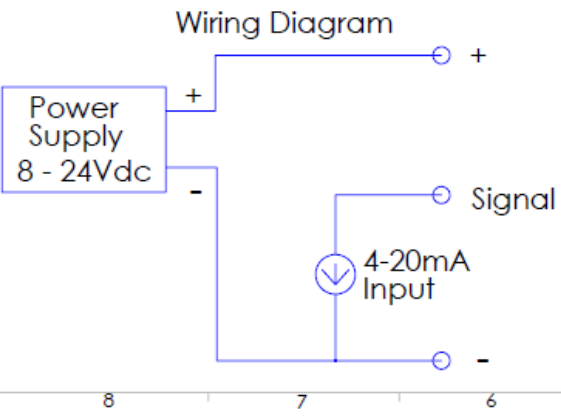

UNLESS OTHERWISE SPECIFIED
BREAK ALL EDGES .010 INCHES
MAX.
DO NOT SCALE DRAWING
INTERPRET DWG
3RD ANGLE PROJECTION

UNLESS OTHERWISE SPECIFIED
DIMENSIONS ARE IN INCHES
TOLERANCES ARE:
FRACTIONS DECIMALS ANGLES
+/- 1/16 .X +/- .030 +/- 1
.XX +/- .015
.XXX +/- .005
MATERIAL
FINISH
UNLESS OTHERWISE SPECIFIED

CAD GENERATED DRAWING,
DO NOT
MANUALLY UPDATE

NRG SYSTEMS

5547_Classic TCS Installation simulation

DRAWN	RESPONSIBLE ENG APPROVAL	SHEET SIZE	PART #	REV.
--	--	A	5547	A

SCALE --- CAD FILE: 5547_Classic TCS Installation simulation
FOLDER: C:\NRG Vault\NRG Vault\Engineering Files\5500\

SHEET **3 OF 3**

Technical Specifications

Description	Sensor type	Yaw Control Wind Direction Vane
	Applications	<ul style="list-style-type: none"> Measuring relative wind direction for Wind Turbine active yaw control wind direction measurement for programmable logic controllers environmental monitoring
	Sensor range	0° to 360°, continuous rotation
	Instrument compatibility	Controllers or data loggers with 4 - 20 mA current loop inputs
	Certifications	CE marked
Output signal	Signal type	current loop, 4 to 20 mA, sourced by the sensor
	Transfer function	<ul style="list-style-type: none"> 4 to 20 mA corresponds to 0° to 360° Recommended orientation sets 180° toward rotor
	Accuracy	<ul style="list-style-type: none"> calibration for mid-range (180° = 12 mA): +/- 0.4 % absolute linearity 0.2% or better from 160° to 200° absolute linearity 1% through the rest of the range
	Dead band	2° max.
	Recommended load resistance	<ul style="list-style-type: none"> 250 Ohms maximum with minimum 7 V power supply 1000 Ohms maximum with 24 V power
	Calibration	Factory calibration of 180° position to 12 mA output
	Output signal range	4 to 20 mA for 0° to 360°
	Resolution	10 bits; < 0.4 °
Response characteristics	Threshold	1 m/s (2.2 miles per hour)
Power requirements	Supply voltage	7 to 27 V DC, for use on 12 or 24 V DC supplies.
	Supply current	40 mA max, plus the output signal current
Installation	Mounting	onto a 13 mm (0.5 inch) diameter hollow mast with cotter pin and set screw
	Tools required	<ul style="list-style-type: none"> #2 Phillips screwdriver for set screw 0.25" nut driver for terminal nuts
	Accessories	Terminal boot
	Wiring	to 4-40 threaded posts (2.7 mm diameter) with nuts
Environmental	Operating temperature range	-40 to +125 C
	Lifespan	> 100 million revolutions
Physical	Connections	4-40 threaded tin-plated phosphor bronze posts with nuts
	Dimensions	<ul style="list-style-type: none"> 21 cm (8.3 inches) length x 12 cm (4.3 inches) high 27 cm (10.5 inches) swept diameter
Materials	Wing	Black, UV-stabilized plastic
	Body	Black, UV-stabilized, static-dissipating plastic
	Shaft	stainless steel
	Bearing	precision stainless steel ball bearings
	Boot	protective PVC sensor terminal boot included
	Terminals	<ul style="list-style-type: none"> tin plated phosphor bronze studs nickel plated brass nuts

Appendix A: Grounding and Bonding NRG Systems Classic Turbine Control sensors for lightning and over-voltage protection

Introduction

This appendix outlines NRG's recommended practices for wiring, grounding, and bonding of NRG Systems Classic turbine control sensors. The goal is to provide the best possible protection against direct and indirect lightning and ESD damage for both the sensors and the interconnected turbine systems.

Recommended Practices

The long-term reliability and the Electromagnetic Compatibility (EMC) performance of the sensors are dependent on proper installation and connections. These recommendations could apply to any control electronics or sensors, but are particularly critical for wind turbine control sensors because they are exposed on the top of the nacelle.

1. IEC 62305-1:2011 defines several Lightning Protection Zones (LPZ). LPZ 0_A is exposed on the surface of the turbine and is subject to direct lightning attachment. The turbine must provide air terminals such as lightning rods to protect the sensors from direct lightning attachment. This creates an area in LPZ 0_B to mount the sensors.
2. Careful routing of the lightning down-conductor and coordination of the grounding and bonding of the down-conductor(s) to the turbine's Lightning Protection System (LPS) is required to minimize the energy coupled into other systems such as the sensors. Provide maximum possible spacing between lightning down-conductors and any control cabling or raceway. Do not route any other cabling or raceway alongside the lightning down-conductors. These measures will minimize the coupling of lightning electromagnetic pulse (LEMP) energy into other turbine systems.
3. The 20H sensor body is static dissipative plastic, but is not conductive. The internal metal parts of the sensors are bonded to the common ground terminal of the sensor.
4. The mounting mast must be metal. Take particular care to bond the sensor mounting mast to the turbine's LPS in coordination with the placement and bonding of the lightning air terminals and bonding of the turbine frame and nacelle.
5. Run the sensor cabling in metallic raceway or conduit. Bond the raceway or conduit to the LPS at both ends. This provides protection for the sensor and cabling against EMI and LEMP. Use shielded or "screened" cable with high shield coverage for sensor cabling. We recommend that the shield always be connected at the controller end of the cable. This provides shielding against capacitively (electrostatically) coupled interference to the sensor signal.

If the shield can be connected to ground at the sensor boom as well, the shield can also provide protection against inductive (magnetically) coupled noise sources, such as generator noise and lightning electromagnetic pulses. However, you should connect the shield at both ends only if the turbine grounding system provides sufficient bonding and grounding to prevent ground loop currents in the shield wire.

6. Provide sufficient bonding to prevent ground loop currents in the shields and raceways. Whenever possible, it is better to resolve an underlying grounding problem, rather than leaving the shield unconnected to prevent ground loop current flow.

7. Since the sensors are in LPZ 0_B, it is important to provide adequate isolation and over-voltage protection (OVP) at the sensors' connections to the control system, to provide LPZ 1 or better protection for the controller.

References

1. IEC 62305-1: 2011: *Protection against lightning - Part 1: General principles*
2. IEC 61400-24 ed1.0: *Wind Turbine Generator Systems- Part 24: Lightning Protection.*
3. IEC 61312-1: 1995: *Protection against Lightning Electromagnetic Impulse- Part 1: General Principles*

Appendix B: Warranty & Repair

Two Year Limited Warranty

NRG Systems, Inc. (NRG) warrants its products for a period of two years from the date of original purchase solely for the benefit of the original consumer purchaser. If this NRG product is determined to be defective in materials or workmanship, NRG will, at NRG's option, repair or replace this product without charge. This warranty does not cover damage due to improper installation or use, accident or misuse, lightning or damages due to any unauthorized service. This warranty also will not apply if any seal on any instrument or sensor is broken or the equipment is not grounded.

To return a defective product, call NRG Systems at the telephone number listed below for an RMA number. You must have available when you call the serial number of the item as well as the date purchased. *No products will be accepted for warranty work without an RMA number.* The product must be returned, postage prepaid, to NRG. Include a brief description of the problem, RMA number and a return address with phone number.

The foregoing limited warranty is given in lieu of all other warranties, express or implied. NRG specifically disclaims all implied warranties, including, but not limited to, any implied warranties of merchantability and fitness for a particular purpose.

The above limited warranty expressly excludes, and NRG shall not be liable for, any incidental or consequential damages caused or related to the use of, inability to use or malfunction of this product.

Prompt disposition: NRG will make a good faith effort for prompt correction or other adjustment with respect to any product which proves to be defective within warranty. First contact NRG or representative from whom product was purchased and ask for an RMA number.

NRG will also make a good faith effort for prompt service after the warranty period. Contact NRG with the nature of the problem and obtain an RMA number.

Inspect your shipments for damaged or missing packages immediately upon receipt. Record any such exceptions on the freight receipt of the delivery agent. If any contents are damaged or missing, report this in writing to the freight carrier and send NRG a copy of the damage report. If you insured the shipment yourself, report any damages to your insurance carrier.

TEL: 802-482-2255 FAX: 802-482-2272 EMAIL: sales@nrghsystems.com

Sending Repair Items to NRG Systems

INTERNATIONAL CUSTOMERS

- Contact NRG Systems to obtain an RMA number** (Return Material Authorization). Write the RMA number clearly on all shipping cartons.
- Send your item to NRG Systems "Delivery Duty Paid"** to NRG Systems (see address below) using a door-to-door courier service such as UPS, FedEx, or DHL. If the repair is not urgent, please send your package by Airmail. (Courier services deliver the package directly to us, customs cleared.)
 - NRG will not accept packages shipped Freight Collect or with Collect charges.**
If NRG refuses the shipment, the courier service will charge your account return freight charges.
 - DO NOT send return items by direct or consolidated air freight service with an airline.**
The cost for air freight may seem lower than the courier service, but air freight costs do not include customs clearance, airport handling, break bulk fees, and inland delivery to NRG Systems.
- Attach a Commercial Invoice** to the carton. The Commercial Invoice should include the following information:
 - Name and address of the shipper.
 - NRG Systems' complete address and telephone number as the consignee.
 - Description of the items being returned.
 - Quantity of each item being returned.
 - Value for customs / insurance (purchase price or replacement cost).
 - Number of cartons with respective weights and dimensions.
 - Please include the following statement to avoid paying US import duties:

"These items are being returned to their U.S. manufacturer. Country of manufacture and origin is USA, HTS CODE 9801.00.1012."
- Pack your repair item in a sturdy packing carton.** Tag each item with a brief description of the problem.
- Insure your shipment** against damage or loss in transit. Be sure to check the appropriate box and enter a "Value for Carriage" (insurance) on your air waybill. The value is the purchase price of the equipment or what it would cost to replace the equipment if the shipment were lost. Keep a record of the tracking number.

Once your item arrives, we will assess the item and notify you of the repair cost. Any repair charges and freight costs, if applicable, are payable before NRG Systems will return the repaired item to you via door-to-door courier service. NRG Systems will send you a shipment advisement when the repaired item is shipped.

International Customers:

Before sending the repair item to NRG Systems, check with your local customs authorities about provisions in your country for exporting and re-importing repair items. Some countries treat repair shipments like new shipments and charge import duties and taxes again upon re-importation. Other countries have specific steps to follow or specific forms to complete which help reduce the import duties upon re-import of the item.

US CUSTOMERS

Please see items 1, 4, and 5 above. Send your item(s) to NRG Systems "Freight Prepaid and Insured."

Shipments sent freight collect will not be accepted by NRG Systems.

NRG Systems, Inc.

**Attn: RMA- _____
110 Riggs Road
Hinesburg VT 05461 USA**

Declaration of Conformity

(in accordance with ISO/IEC 17050-1:2004)

NRG Systems Document Number: 5586, Rev A

Supplier: NRG Systems
 Supplier Address: 110 Riggs Road, Hinesburg, VT 05461, USA
 Telephone: 802 482 2255, Fax: 802 482 2272
 Email: sales@nrgsystems.com

Declares that the Products: Classic Turbine Control Sensors, including:

20H Turbine Control Vane	Item 5347
40H Anemometer	Item 1798

are in conformity with the requirements of the following documents:

EN61326-1 Class A "Electrical Equipment for Measurement, Control, and Laboratory Use—EMC Requirements", in accordance with: CISPR 11; EN 61000-4-2; EN 61000-4-3; EN 61000-4-4; 61000-4-6; EN 61000-4-8

IEC 61010-1 "Safety requirements for electrical equipment for measurement, control, and laboratory use"

Additional Information:

These products comply with the requirements of the applicable directives 2006/42/EC, 2004/108/EC, 2002/96/EC, and standard EN 61010-1 and therefore, the product is CE marked in accordance with 93/68/EEC.

FCC compliance is demonstrated with compliant CISPR data.

The design documentation, test reports, and assessment laboratory accreditation are on file with Mr. Barry King Electrical Engineer.

Issued at Hinesburg, VT, USA
 7 September 2011

 Owen Clay
 Engineering Manager

Tel 802.482.2255 | Fax 802.482.2272 | info@nrgsystems.com | 110 Riggs Road, Hinesburg, Vermont 05461 USA | www.nrgsystems.com



This sensor contains lead solder. Dispose of waste electronics by proper recycling or return to NRG for disposal.