

Soiling Measurement Kit: PSM1

INSTRUCTIONS



110 Riggs Road
Hinesburg, VT 05462 USA
support@nrgsystems.com
+1 802.482.2255 | nrgsystems.com



CONTENTS

SENSOR/PRODUCT IDENTIFICATION 5

- #19045 SRM Crystalline 30A PSM: Parts 5*
- #19046 SRM Thin Film 4A PSM: Parts 6*
- #19047 SRM 30W Array PSM: Parts 6*
- #19048 SRA 30W Tower PSM: Parts 6*
- #18890 Subassembly: DC Isolator or “Solar Disconnect” 7*
- Additional Parts Necessary for Symphonie PRO (if installing on Channels 20-26)..... 7*

SAFETY CONSIDERATIONS / WARNINGS..... 8

OPERATING ENVIRONMENTAL CONDITIONS 9

INSTALLATION 10

- Considerations 10**
 - Location 10*
 - Brackets / Mounting Fasteners 10*
 - Tools 10*
 - Compatibility 11*
- Thin Film/Crystalline PSM1 installation 12**
- NRG 30 W PSM installation 18**
- Wiring and Configuration 19**
 - Wiring LOGR-S: 19*
 - Programming LOGR-S: 20*
 - LOGR-S Analog Channel Configuration Tables 21*
 - Final LOGR-S Checks:..... 25*
- SymphoniePRO logger Configuration:..... 26**
 - Wiring Analog Channels 16-19 & 20-26: 26*
 - Programming SymphoniePRO: 27*
 - SymphoniePRO Logger Configuration Table (Analog Channels 16-19 & P-SCM Channels 20-26):..... 28*
 - Final SymphoniePRO Checks: 29*

OPERATION OF THE SYSTEM 29

- Cleaning the “Clean” panel..... 29**



Sensors | Pulsed Soiling Module (PSM1)

Data Processing – Soiling Calculation..... 30

MAINTENANCE AND SERVICE..... 30

PSM1 Maintenance..... 30

TECHNICAL SPECIFICATIONS 30

CONTACT INFORMATION..... 33



Sensors | Pulsed Soiling Module (PSM1)

INTRODUCTION

The Pulsed Soiling Module (PSM1) measures the Open Circuit Voltage and Short Circuit Current of a clean and soiled solar panel in accordance with IEC 61724-1. The equipment is intended to be used outdoors and is mounted on or near a solar panel array. Equipment is intended to be used with NRG data loggers.

Throughout these instructions and on NRG's website, you will see the PSM1 referred to as Soiling Measurement Kit or PSM. Please note that these refer to the same product and are used interchangeably throughout this document.

There are two PSM1 models, Crystalline and Thin Film.

- Crystalline
 - Holds panels in open circuit
 - Pulses short circuit current – 50 milliseconds every two seconds.
 - Intended for low to medium voltage and high currents
 - High and low power Crystalline PV panels
- Thin Film
 - Holds panels in short circuit
 - Pulses open circuit voltage – 50 milliseconds every two seconds.
 - Intended for high voltage and low to medium currents
 - High power Thin Film PV panels

Manufacturer not responsible for device malfunction if device is not used as intended.



SENSOR/PRODUCT IDENTIFICATION

PSM labels identify company, product, input and output values, and shock hazards. An example of the PSM1’s labeling is shown below. Details vary depending on the PSM1 kit.



PSM1 Solar Kits:

#19045 SRM Crystalline 30A PSM: Parts

NRG Part Number	Part Description	Part Specification	Qty
18872	Pulsed Soiling Module	PSM1, Crystalline Assembly	1
18888	Cable	30m cable	1
18890	DC Isolator (Disconnect) Sub-Assembly	64 Amp	1
18904	Solar Button	3m, Array Mounted	1
9424	PVT1 BoM Temp Sensor	50m cable	2



Sensors | Pulsed Soiling Module (PSM1)

#19046 SRM Thin Film 4A PSM: Parts

NRG Part Number	Part Description	Part Specification	Qty
18860	Pulsed Soiling Module	PSM1, Thin Film Assembly	1
18888	Cable	30m cable	1
18890	DC Isolator (Disconnect) Sub-Assembly	64 Amp	1
18904	Solar Button	3m, Array Mounted	1
9424	PVT1 BoM Temp Sensor	50m cable	2

#19047 SRM 30W Array PSM: Parts

NRG Part Number	Part Description	Part Specification	Qty
18872	Pulsed Soiling Module	PSM1, Crystalline Assembly	1
18888	Cable	30m cable	1
18887	PV Panels	30W, MC4 connectors	1
18904	Solar Button	3m, Array Mounted	1
9424	PVT1 BoM Temp Sensor	50m cable	2

#19048 SRA 30W Tower PSM: Parts

NRG Part Number	Part Description	Part Specification	Qty
18872	Pulsed Soiling Module	PSM1, Crystalline Assembly	1
18889	Cable	2m cable	1
18887	PV Panels	30W, MC4 connectors	1
18904	Solar Button	3m, Array Mounted	1
9424	PVT1 BoM Temp Sensor	3m cable	2
18900	Soiling Station Mount	Tube mount bracket, U-bolt	1



Sensors | Pulsed Soiling Module (PSM1)

#18890 Subassembly: DC Isolator or "Solar Disconnect"

NRG Part Number	Part Description	Part Specification	Qty
18623	Solar Disconnect	64 A, SRM	1
11044	Outdoor Label	CLEAN	1
11046	Outdoor Label	DIRTY	1
18718	Mount	Solar Disconnect	2
18695	Label	Solar Disconnect	1
19156	MC4 cable	Solar Ext. Cable Pair, 10ga., 5'	4
19157	MC4 cable	Solar Ext. Cable Pair, 10ga., 10'	4
2703	Hose Clamp	#164, 2.0"-10.75", 9/16 Hex/Slotted Screw, SS	2



Additional Parts Necessary for Symphonie PRO (if installing on Channels 20-26)











NRG Part Number	Part Description	Part Specification	Qty
9132	P-SCM Card	PCBA Assy, P-SCM, 0 to 5 V Input, Constant 12V Exc,	2



SAFETY CONSIDERATIONS / WARNINGS





Warning symbols:

	This universal symbol represents a general warning and is marked on the unit and included in this manual.
	This universal symbol represents an electrical hazard and is marked on the unit and included in this manual. Care should be taken to avoid coming into contact with electricity.
	This universal symbol signifies that the user manual must be read and is marked on the unit.

WARNING: 	Observe safety precautions: Failure to observe precautions may result in bodily injury and/or damage to the product or interconnected equipment.
WARNING: 	Follow directions: Operate this equipment only as directed in these instructions.
WARNING: 	Inspect before using: Inspect the equipment and note any damage or defects, including in wiring. Do not use the equipment if damaged or defective.
WARNING:  	Hazardous voltages: PV modules may produce hazardous voltages and currents. Hazardous voltages may be present within the product or its connections. Improper use risks fire or electric shock which could cause bodily injury.
WARNING:  	Qualified personnel only: The product should only be installed and serviced by trained and qualified personnel.
WARNING: 	DO NOT CONNECT OR DISCONNECT PV MODULES UNDER LOAD: PV modules must be disconnected through a DC Isolator / Switch or otherwise prevented from producing power during installation or servicing of this product.
WARNING: 	Do not exceed module voltage or current ratings: To prevent damage to the product, ensure that the PV module connected to the inputs never exceeds the product's listed voltage and current ratings.
WARNING: 	Secure PV module connections: PV module connections must be properly mated and secured.



Sensors | Pulsed Soiling Module (PSM1)

<p>WARNING:</p>  	<p>Do not open the enclosure: There are no user-serviceable parts inside the product enclosure. Do not open it. Opening the enclosure may damage the product and/or interconnected equipment and risks bodily injury.</p>
<p>WARNING:</p> 	<p>Follow standard safety rules: Follow all other standard safety rules for your PV array installation, in addition to the specific precautions listed here.</p>
<p>WARNING:</p> 	<p>Protective Conductor must be connected: The products protective conductor must be connected before PV modules are installed. Disconnection of protective conductor while product is connected to PV modules risks bodily injury.</p>

OPERATING ENVIRONMENTAL CONDITIONS

The Pulsed Soiling Module is designed for outdoor use. Detailed operating conditions are tabulated in the Technical Specifications section, p.26.



INSTALLATION

Considerations

Location

- Product is intended to be mounted to the pile, with the Solar Disconnect (if applicable) on the torque tube.
- The standard 18634 MC4 cables that run from the PV modules to the Solar Disconnect to the PSM are 2 meters long.
 - These can change by up to 0.5 m in length. To ensure that cable runs will reach the Solar Disconnect and PSM, lay the cables out roughly where they will be permanently installed. Once you've ensured cable length is correct, plug cables in to the PSM and Solar Disconnect and manage cables as necessary.
- The Solar Disconnect shall be mounted in full view of the PSM and in a location where the ON/OFF dial on the front can be accessed.

Brackets / Mounting Fasteners

- All brackets are provided in the standard kits assuming the system is mounted as designed.
- Technicians may want to bring cable management accessories (e.g. zip ties) to keep cable routing organized.

Tools

- Both power and hand screw drivers will be required.
 - Both flathead and Phillips heads may be required.
- Grounding screw is a self-drilling #10 screw but may still require a pre-drilled hole for some materials/thicknesses. A drill bit size of 1/8th inch can be used.
- 3 mm nut driver for tightening of #2703 Hose Clamps
- Ethernet cable (LOGR-S)
- USB A-B cable (SymphoniePRO)



Sensors | Pulsed Soiling Module (PSM1)

Compatibility

- Data Logger Compatibility
 - NRG LOGR-S
 - NRG SymphoniePRO Logger
 - Any Data Logger which supports:
 - 8-28 VDC, 20 mA Excitation
 - Four 0 to 5 V Analog Inputs
- PV Module Compatibility
 - Crystalline PV Modules (including bifacial modules)
 - Maximum Open Circuit Voltage of 450 VDC
 - Maximum Short Circuit Current of 30 ADC
 - Thin Film PV Modules (including bifacial modules)
 - Maximum Open Circuit Voltage of 450 VDC
 - Maximum Short Circuit Current of 4 ADC



Sensors | Pulsed Soiling Module (PSM1)

Thin Film/Crystalline PSM1 installation

The following are step-by-step instructions for installing NRG Solar Kits **19045** and **19046**. These both require a DC disconnect or “isolator” (see image below). The NRG kit number is #18890. The DC disconnect item number is #18623.

⚠ WARNING: Hazardous voltages: PV modules may produce hazardous voltages and currents. Hazardous voltages may be present within the product or its connections. Improper use risks fire or electric shock which could cause bodily injury.



Item #18623 Solar Disconnect.

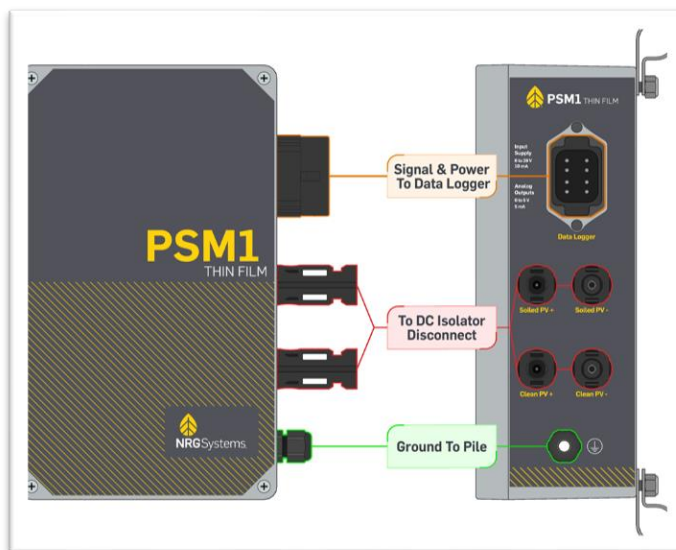

PSM connections



Sensors | Pulsed Soiling Module (PSM1)

1. Begin by loosely outlining where the various components will be installed and check cable lengths.
2. The #18890 – **Solar Disconnect**, should be mounted onto the torque tube near the two Soiling PV panels. Use the two provided #2703 – hose clamps.

 **WARNING:** Ensure 18623 Solar Disconnect is turned to the OFF position.

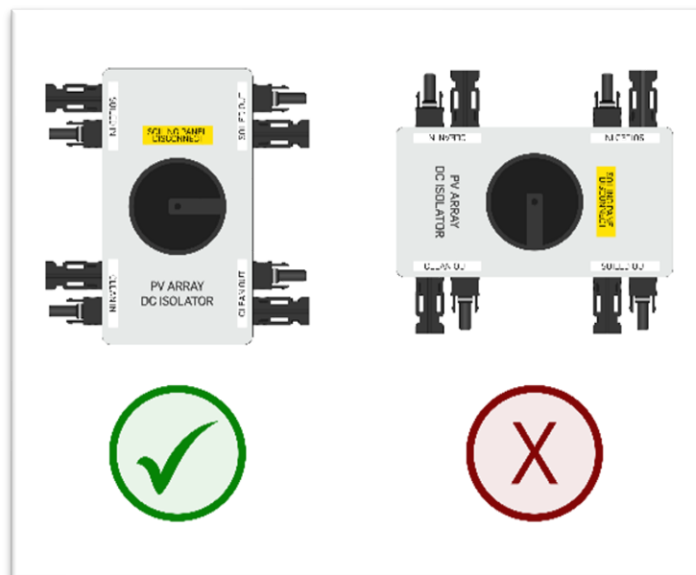

DC Isolator - Acceptable Mounting Orientations

3. Connect the “Soiled” and “Clean” PV panels to the **18623 - Solar Disconnect** using the **MC4 cables**.

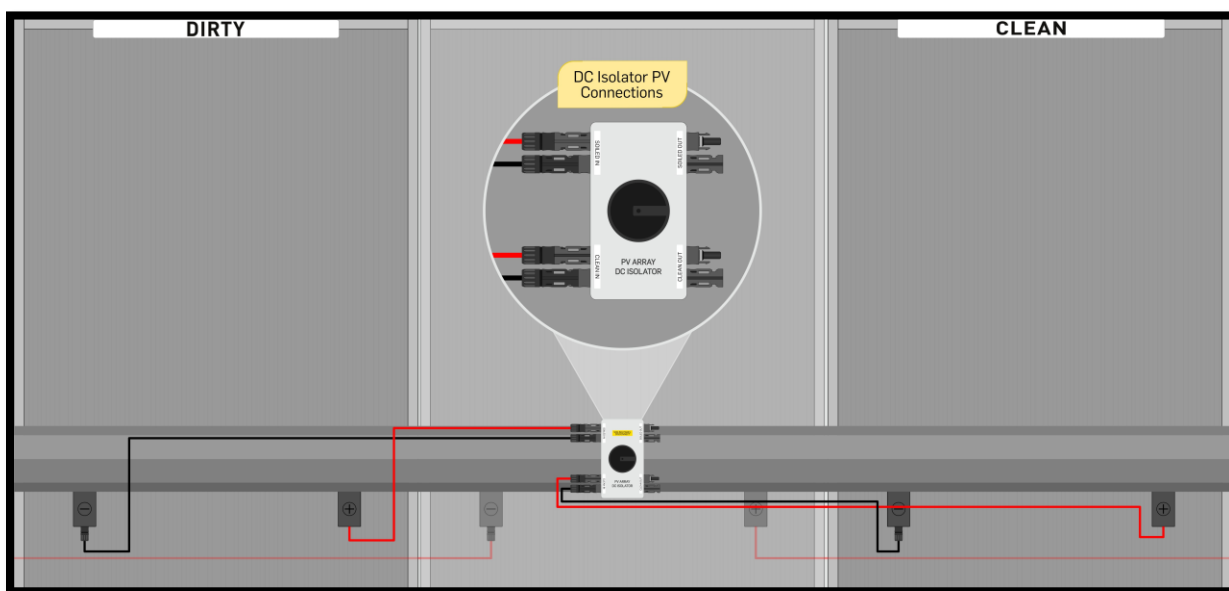

Example DC Isolator Location



Sensors | Pulsed Soiling Module (PSM1)

4. Mount the PSM onto the pile nearest to the DC Isolator, again using the provided hose clamps. The PSM may also be mounted to the Torque tube if there are cabling restrictions, be mindful of the suggested orientation.

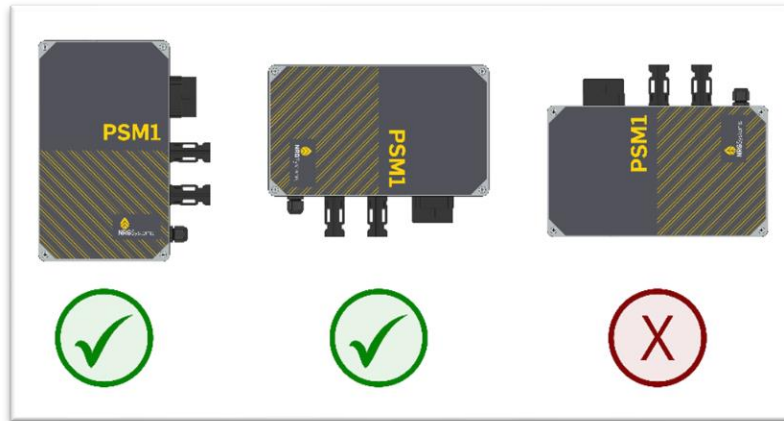

Pulse Soiling Module - Mounting Orientations



PSM - Pile Mounted with Hose Clamps



Sensors | Pulsed Soiling Module (PSM1)

- Next, make sure that the grounding cable is affixed to chosen earth ground. You may need to drill a hole in the pile or grounding structure to attach the ground cable. The grounding cable should not be connected to the logger.

⚠️ WARNING: This is a safety critical step. Not connecting the PSM1 to earth ground may cause the PSM1 to be a shock hazard.

⚠️ WARNING: Ensure 18623 Solar Disconnect is turned to the OFF position

- Connect PSM to the **18623 - Solar Disconnect** utilizing **MC4 cables**.
 - Ensure “Soiled” and “Clean” output from the disconnect are going to the corresponding PSM ports.

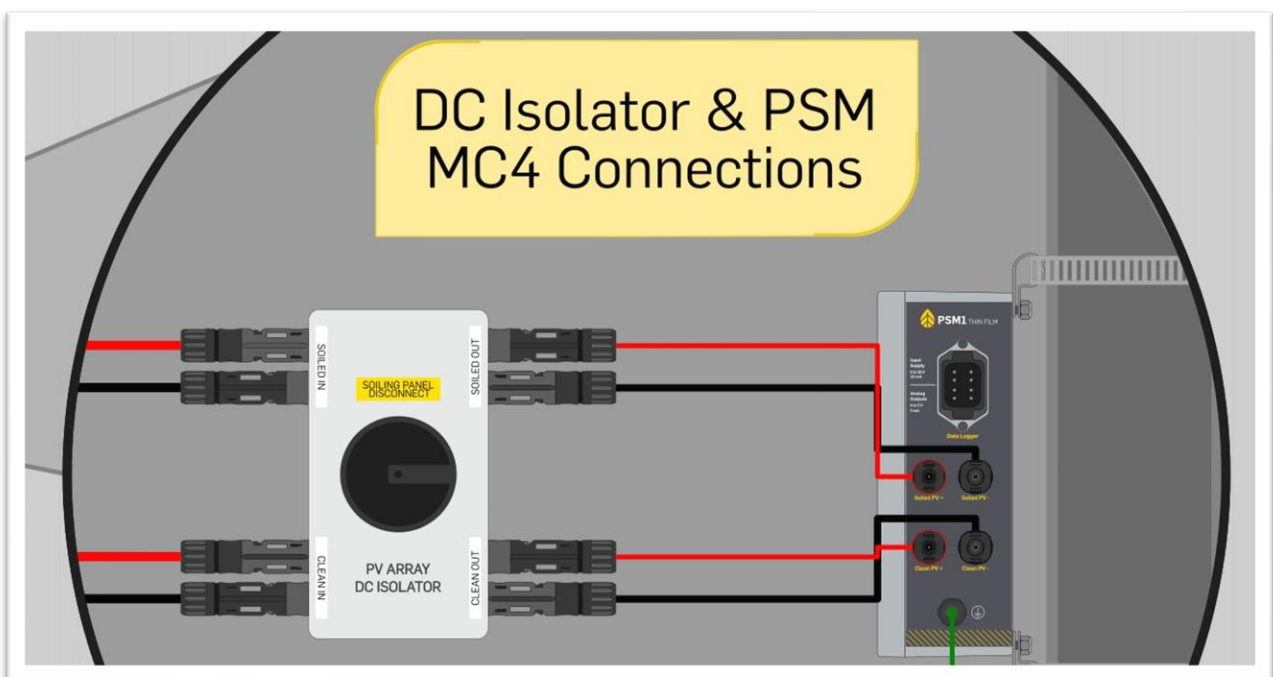



Sensors | Pulsed Soiling Module (PSM1)

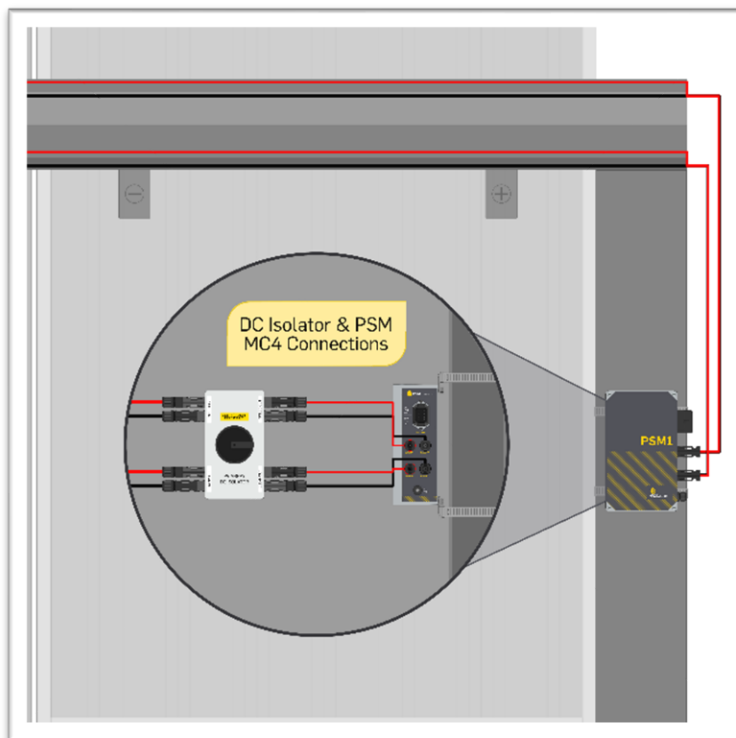

DC Isolator & PSM MC4 Connections on PV array

6. Connect PSM1 to the LOGR-S using 18647 - *30-meter Power & Signal Cable*.



Close up of 8-pin connector. Please note: when unplugging connector, the orange seal may come off. If this comes off after disconnection, make sure to re-attach this piece.

 **WARNING:** Seal provides ingress protection against liquids. If liquid water or conductive contaminates gets inside the PSM1, it may cause arcing across terminals not designed to handle high voltages (e.g. sending 450 V to the attached logger to ground).



Sensors | Pulsed Soiling Module (PSM1)

7. Connect “Soiled” and “Clean” PV modules to the Solar Disconnect utilizing **MC4 cables**. Ensure “Soiled” and “Clean” output from the disconnect are going to the corresponding PSM ports.
8. Turn the **#18623 Solar Disconnect** to ON.

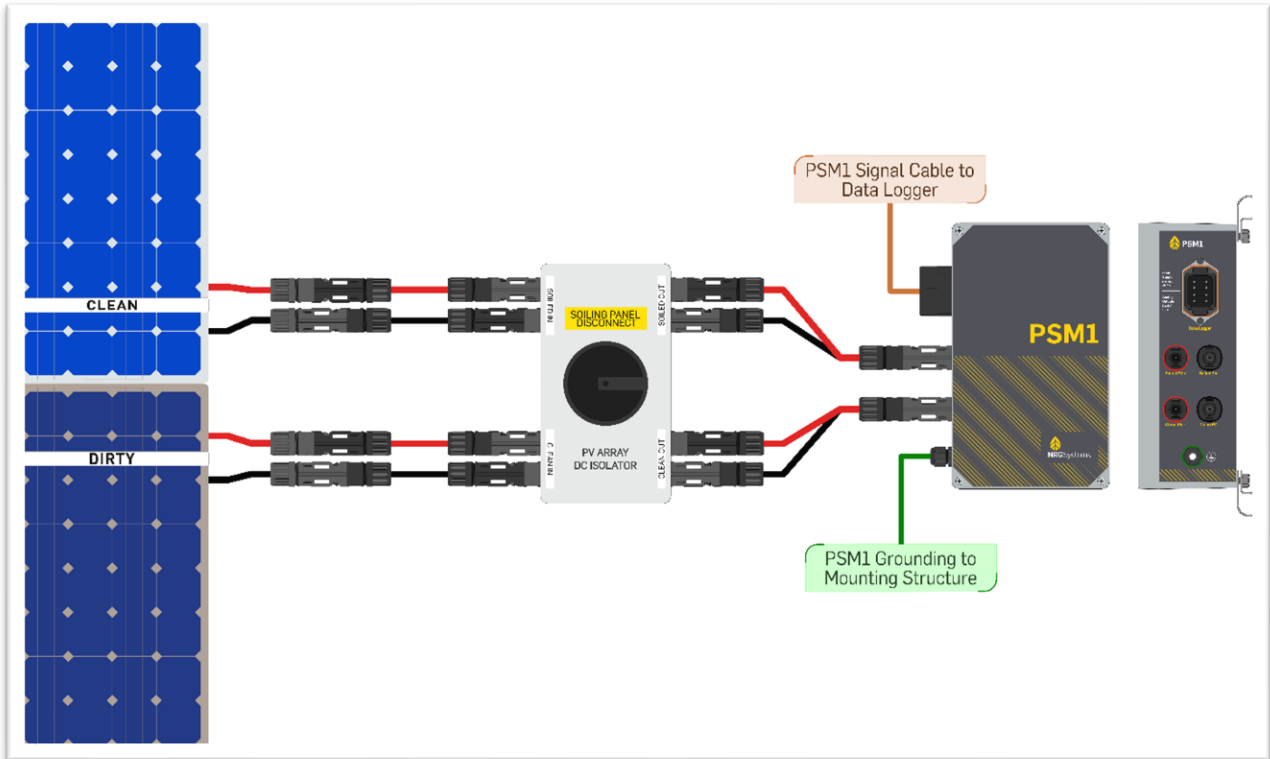

Complete assembly of PSM1 for Crystalline and Thin Film Configurations.



Sensors | Pulsed Soiling Module (PSM1)

NRG 30 W PSM installation

The following are step-by-step instructions for installing NRG Solar Kit **19048**. This kit does not require a **Solar Disconnect (18623)** or corresponding sub-assembly (**#18890**).

1. Attach PSM to chosen location using the provided **NRG #2703 hose clamps**.
 - a. Attach grounding cable to chosen earth ground.
2. Connect PSM to the low power solar panels utilizing **MC4 cables**.
 - a. Ensure “Soiled” and “Clean” labeling are correctly connected between the two units.

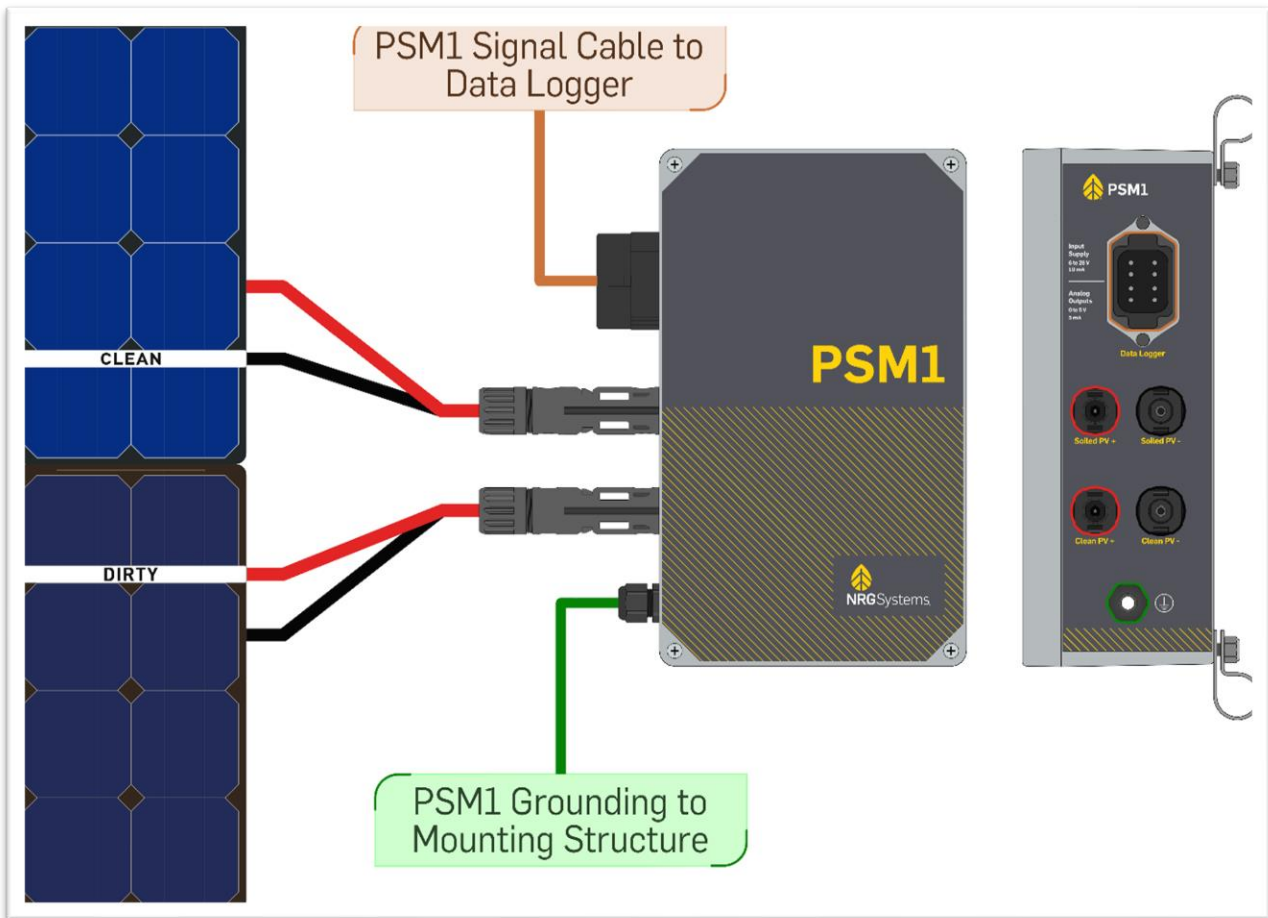

3. Connect the PSM to the LOGR-S using **18647 – 30-meter Power & Signal Cable**. Please note: when unplugging connector, the orange seal may come off. **If this comes off after disconnection, make sure to re-attach this piece.**

 **WARNING:** Seal provides ingress protection. If liquid water or conductive contaminants gets inside the PSM1, it may cause arcing across terminals not designed to handle high voltages (e.g. sending 450 V to the attached logger to ground).



Wiring and Configuration

Wiring LOGR-S:

LOGR-S: Wiring Table - Analog		
Wire Color	Function	Termination
Red	Power Excitation	1 st Port - EXC
Black	Power Ground	1 st Port - GND
Blue	Soiled Isc	1 st Port - SIG+
Green	Soiled Voc	1 st Port - SIG
Shield	Cable Shield	1 st Port - SHD
Yellow	Clean Isc	2 nd Port - SIG+
Brown	Clean Voc	2 nd Port - SIG

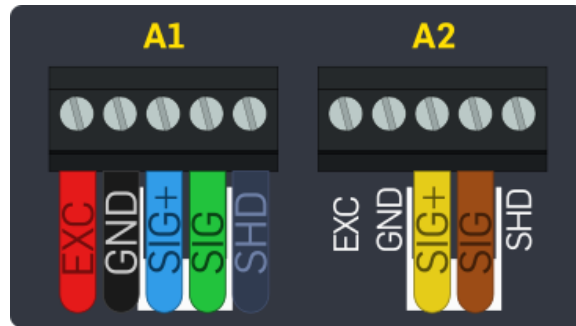

LOGR-S, Analog, Sensor Wiring



Sensors | Pulsed Soiling Module (PSM1)

Programming LOGR-S:

Open a web browser and connect the logger using an Ethernet cable directly to the laptop or secure a wireless connection via static IP address while connected to the same local network as the logger. Enter the static IP address in the browser URL bar. If this is an unconfigured LOGR-S, the default IP address is **192.168.1.110**. When connected, the browser will direct to the home Sensor Output page of the specified logger.

Navigate to **Logger > Firmware** to ensure that the latest firmware is installed, 1.07.20 or greater.

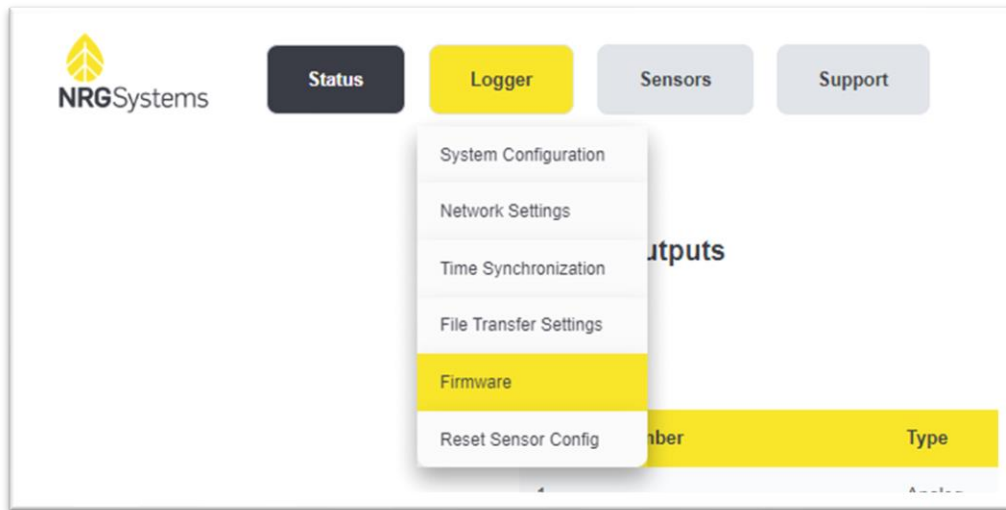



Sensors | Pulsed Soiling Module (PSM1)

Navigate to **Sensors > Analog** channels to configure Isc and Voc Soiled and Clean and associated PVT1 channels. Use the table below to configure the channels based on PV module.

LOGR-S Analog Channel Configuration Tables

30 W PV Module	1st Channel	2nd Channel	3rd Channel	4th Channel
Sensor Type	PSM NRG-30W IscSoil	PSM ThinFilm VocSoil	PSM NRG-30 W IscClean	PSM NRG-30W VocClean
Description	<i>PSM NRG-30W IscSoil</i>	<i>PSM ThinFilm VocSoil</i>	<i>PSM NRG-30 W IscClean</i>	<i>PSM NRG-30W VocClean</i>
Units	Amps	Volts	Amps	Volts
Slope	6.07790	101.58059	6.07790	101.58059
Offset	-0.00212	0.22331	-0.00212	0.22331

Crystalline PV Module	1st Channel	2nd Channel	3rd Channel	4th Channel
Sensor Type	PSM c-Si Isc Soil	PSM c-Si Voc Soil	PSM c-Si Isc Clean	PSM c-Si Voc Clean
Description	<i>PSM c-Si Isc Soil</i>	<i>PSM c-Si Voc Soil</i>	<i>PSM c-Si Isc Clean</i>	<i>PSM c-Si Voc Clean</i>
Units	Amps	Volts	Amps	Volts
Slope	6.05029	101.40663	6.05029	101.40663
Offset	0.03525	0.25613	0.03525	0.25613

Thin Film PV Module	1st Channel	2nd Channel	3rd Channel	4th Channel
Sensor Type	PSM ThinFilmIscSoil	PSM ThinFilm VocSoil	PSM ThinFilmIscClean	PSM ThinFilm VocClean
Description	<i>PSM ThinFilmIscSoil</i>	<i>PSM ThinFilm VocSoil</i>	<i>PSM ThinFilmIscClean</i>	<i>PSM ThinFilm VocClean</i>
Units	Amps	Volts	Amps	Volts
Slope	6.06928	101.21420	6.06928	101.21420
Offset	0.00130	0.56502	0.00130	0.56502



Sensors | Pulsed Soiling Module (PSM1)

Navigate to **Sensors > Soiling Ratio Setup**

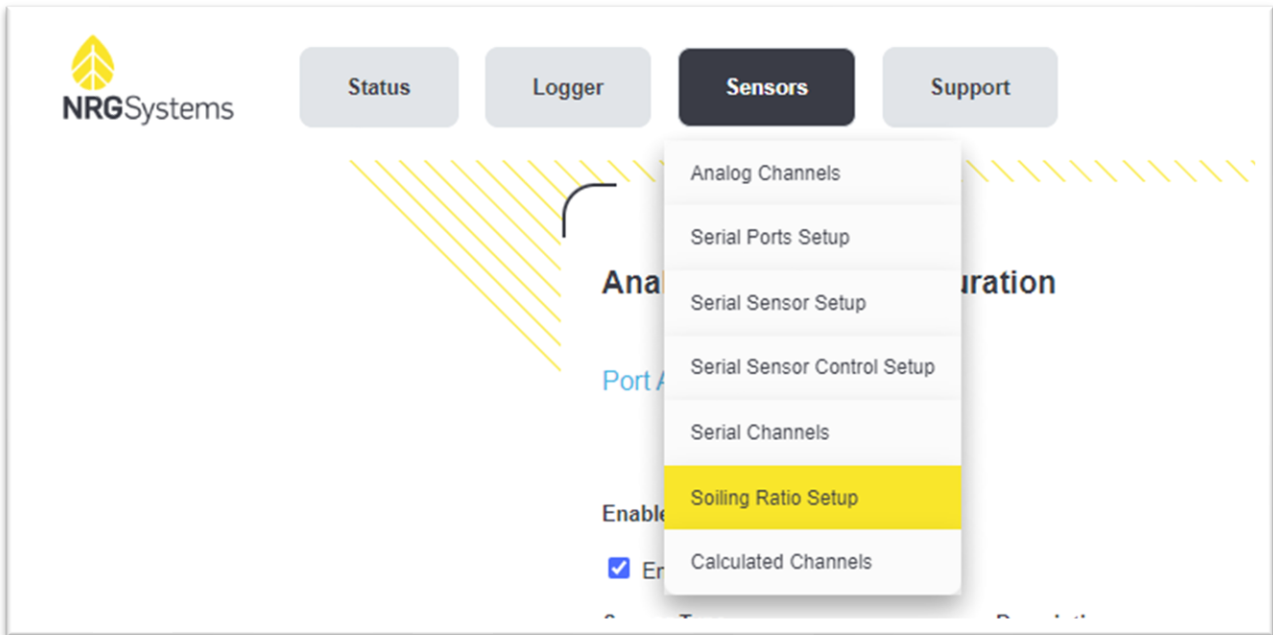

Check box **Compute** under Compute Soiling Ratio and select the IEC 61724 Annex C radio button.

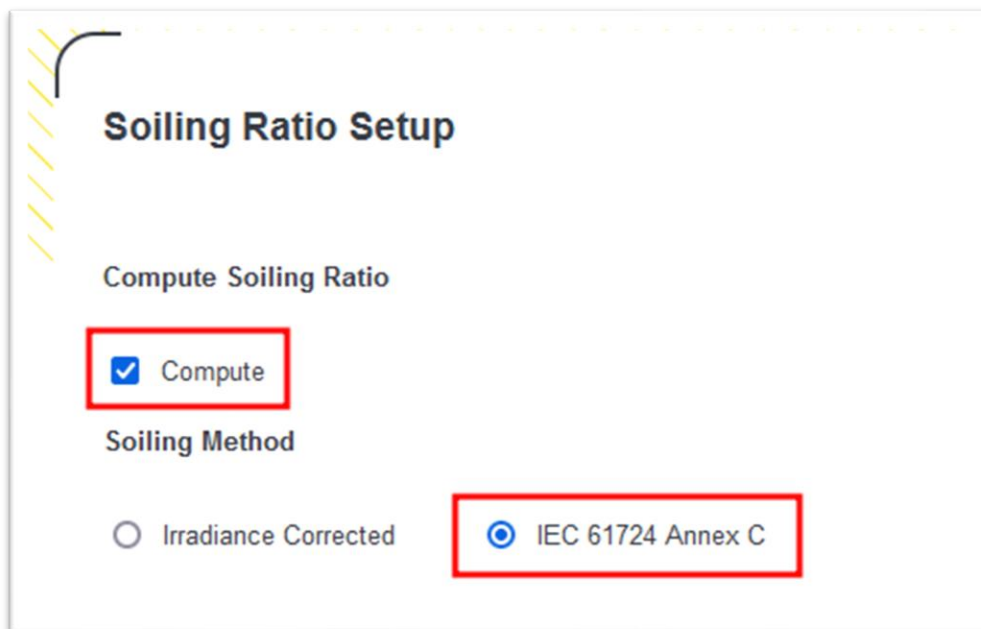



Sensors | Pulsed Soiling Module (PSM1)

Standard Test Conditions for PV Modules should be 25.0 degrees C and 1000 W/m².

Standard Test Conditions STC for PV Modules

Temperature (deg_C)

25.000000 deg_C

Irradiance (W/m²)

1000.000000 W/m²

The PV Panel specifications can be found on a label on the back of the PV panel and can vary from panel to panel. Make sure that this captured information is saved for future reference.

Here is an example of the relevant specifications found on the back of a Thin Film Panel:

FS-6470-P-L stats for PSM programming in LOGR-S

Isc: 2.61 A

Voc: 224.3 V

Temp Coefficient Isc alpha: 0.04%/degree C

Temp Coefficient Voc: -0.28%/degree C



Sensors | Pulsed Soiling Module (PSM1)

The specifications taken from this label are then input into the Clean and Soil PV Module forms below. Use the drop down menus to match the PSM and temperature sensors with their corresponding channels.

Clean PV Module	Soil PV Module
Isc at 1000 W/m ² <input type="text" value="2.610000"/> A	Isc at 1000 W/m ² <input type="text" value="2.610000"/> A
Voc at 1000 W/m ² <input type="text" value="224.300000"/> V	Voc at 1000 W/m ² <input type="text" value="224.300000"/> V
Temperature Coefficient for Isc alpha <input type="text" value="0.040000"/> %/deg_C	Temperature Coefficient for Isc alpha <input type="text" value="0.040000"/> %/deg_C
Temperature Coefficient for Voc <input type="text" value="-0.280000"/> %/deg_C	Temperature Coefficient for Voc <input type="text" value="-0.280000"/> %/deg_C
Description <input type="text" value="Clean PV"/>	Description <input type="text" value="Soiled PV"/>
PSM Isc Input Channel <input type="text" value="3-PSM ThinFilmIscClean"/>	PSM Isc Input Channel <input type="text" value="1-PSM ThinFilm IscSoil"/>
PSM Voc Input Channel <input type="text" value="4-PSM ThinFilmVocClean"/>	PSM Voc Input Channel <input type="text" value="2-PSM ThinFilm VocSoil"/>
PV Temperature Input Channel <input type="text" value="5-NRG PVT1_Clean"/>	PV Temperature Input Channel <input type="text" value="7-NRG PVT1_Soil"/>

IEC Soiling Calculation Filters should be 500 W/m² and 2.0 hours. Click Save in the lower right-hand corner of the browser.

IEC 61724 Soiling Calculation Filter

Include data where irradiance G is greater than

W/m²

Include data within this many hours of solar noon

Hours



Sensors | Pulsed Soiling Module (PSM1)

Check sensor outputs to verify data. Daily Soiling Ratio data should start as close to 1.0 as possible when both modules are cleaned.

209	PV_IEC	Effective Irradiance Clean (G)	424.625 W/Sqm
210	PV_IEC	Soiling Ratio Isc Index (SRIsC)	0.999
211	PV_IEC	Daily Soiling Ratio	0.990

Daily Soiling Ratio would follow the above format in your LOGR-S Sensor Outputs page.

Final LOGR-S Checks:

Pull-test all wires to ensure proper connection. If any of the wires come out of the terminal block during pull-test: loosen the screw, insert the cable, and hand-tighten with a mini flathead screwdriver.

View live data in the right column (**Data**) of the **Sensor Outputs** home page on the web UI and verify that the sensor output is producing reasonable values, and that the units are labeled correctly. If possible, check both ends of the sensor output limits.

5	Analog	PSM NRG-30W IscSoil	0.94 A
6	Analog	PSM NRG-30W VocSoil	20.43 V
7	Analog	PSM NRG-30W IscClean	0.96 A
8	Analog	PSM NRG-30W VocClean	20.44 V

35Watt - Crystalline – Rising sun



Sensors | Pulsed Soiling Module (PSM1)

SymphoniePRO logger Configuration:

This PSM requires four channels to be fully functional. It can be installed on *Analog 5V or 12V Excitation* channels 16-19, or on *Analog P-SCM* channels 20-26. If installed on channels 20-26, it will need the #9132 P-SCM.

Wiring Analog Channels 16-19 & 20-26:

SymphoniePRO: Wiring Table - Analog		
Wire Color	Function	Termination
Red	Power Excitation	EXC
Black	Power Ground	GND
Blue	Soiled Isc	Analog SIG(+) 1
Green	Soiled Voc	Analog SIG(+) 2
Shield	Cable Shield	SHD
Yellow	Clean Isc	Analog SIG(+) 3
Brown	Clean Voc	Analog SIG(+) 4

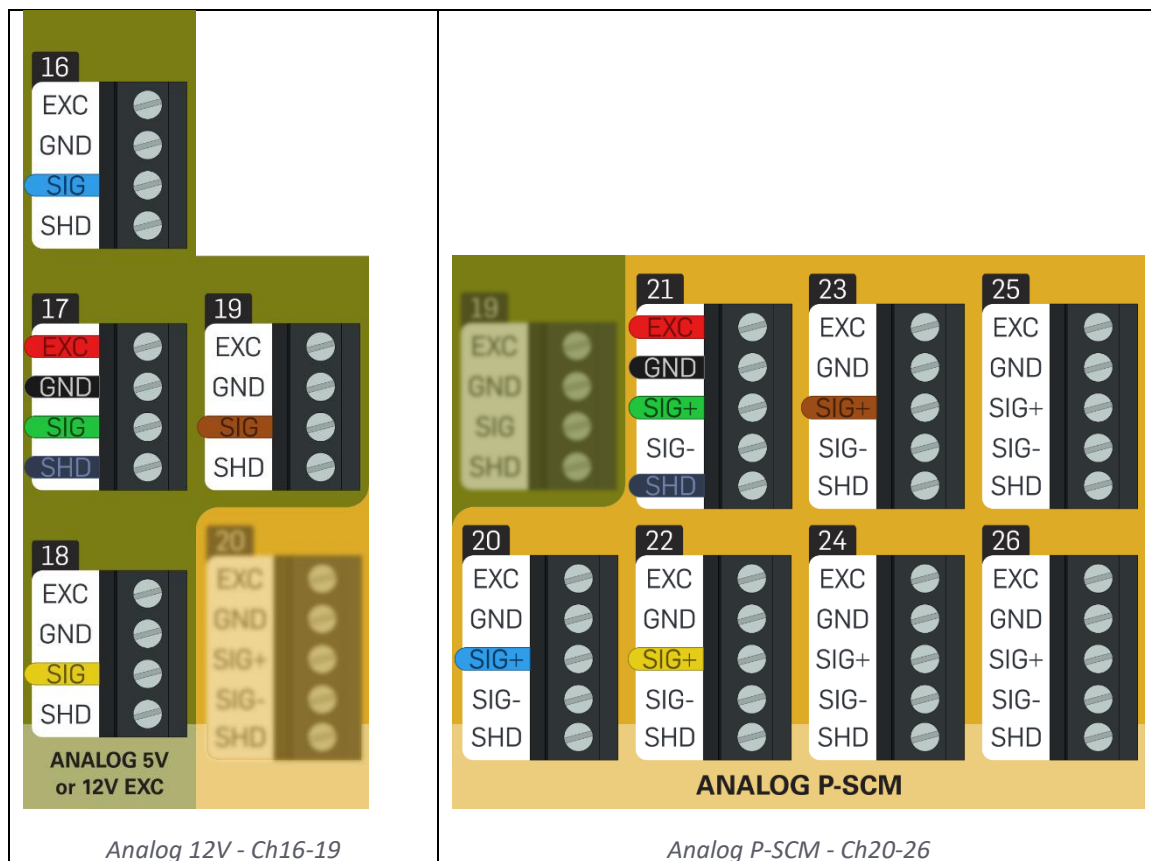



Sensors | Pulsed Soiling Module (PSM1)

Programming SymphoniePRO:

Open the SymphoniePRO Desktop App and connect the logger using a USB cable directly to the laptop or secure a connection via remote Metlink with the iPack static IP address. From the *Fleet View*, enter the logger and navigate to the *Channels* tab located on the left side of the window. Scroll down to the desired channel and begin configuration using the table below to configure the channels based on PV module.



Sensors | Pulsed Soiling Module (PSM1)

SymphoniePRO Logger Configuration Table (Analog Channels 16-19 & P-SCM Channels 20-26):

30 W PV Module	1st Channel	2nd Channel	3rd Channel	4th Channel
Data Logging Mode	Statistics	Statistics	Statistics	Statistics
Channel Type	Analog	Analog	Analog	Analog
Description	<i>NRG PSM Soil Isc</i>	<i>NRG PSM Soil Voc</i>	<i>NRG PSM Clean Isc</i>	<i>NRG PSM Clean Voc</i>
Scale Factor	6.0779	101.5806	6.0779	101.5806
Offset	-0.0021	0.2233	-0.0021	0.2233
Units	Amps	Volts	Amps	Volts
Excitation Mode	Constant On	Constant On	Constant On	Constant On
Voltage	12V	12V	12V	12V
P-SCM	9132 (CH20-26 only)	9132 (CH20-26 only)	9132 (CH20-26 only)	9132 (CH20-26 only)

Crystalline PV Module	1st Channel	2nd Channel	3rd Channel	4th Channel
Data Logging Mode	Statistics	Statistics	Statistics	Statistics
Channel Type	Analog	Analog	Analog	Analog
Description	<i>NRG PSM Soil Isc</i>	<i>NRG PSM Soil Voc</i>	<i>NRG PSM Clean Isc</i>	<i>NRG PSM Clean Voc</i>
Scale Factor	6.0503	101.4066	6.0503	101.4066
Offset	0.0352	0.2561	0.0352	0.2561
Units	Amps	Volts	Amps	Volts
Excitation Mode	Constant On	Constant On	Constant On	Constant On
Voltage	12V	12V	12V	12V
P-SCM	9132 (CH20-26 only)	9132 (CH20-26 only)	9132 (CH20-26 only)	9132 (CH20-26 only)

Thin Film PV Module	1st Channel	2nd Channel	3rd Channel	4th Channel
Data Logging Mode	Statistics	Statistics	Statistics	Statistics
Channel Type	Analog	Analog	Analog	Analog
Description	<i>NRG PSM Soil Isc</i>	<i>NRG PSM Soil Voc</i>	<i>NRG PSM Clean Isc</i>	<i>NRG PSM Clean Voc</i>
Scale Factor	6.0693	101.2142	6.0693	101.2142
Offset	0.0013	0.5650	0.0013	0.5650
Units	Amps	Volts	Amps	Volts
Excitation Mode	Constant On	Constant On	Constant On	Constant On
Voltage	12V	12V	12V	12V
P-SCM	9132 (CH20-26 only)	9132 (CH20-26 only)	9132 (CH20-26 only)	9132 (CH20-26 only)



Sensors | Pulsed Soiling Module (PSM1)

Final SymphoniePRO Checks:

Pull-test all wires to ensure proper connection. If any of the wires come out of the wiring panel during pull-test: loosen the screw, insert the cable, and hand-tighten with a mini flathead screwdriver.

View Live Data (either at the logger display, or via SymphoniePRO Desktop Application) and verify that the sensor output is producing reasonable values, and that the units are labeled correctly. If possible, check both ends of the sensor output limits. Export and view a sample of data to check data is being stored properly.

Analog - V of 12 V excitation										
+	16	Statistics	Analog	Soil Isc	0.00m	0.0 ° (N)	6.0605	0	A	1.02 A
+	17	Statistics	Analog	Soil Voc	0.00m	0.0 ° (N)	101	0	V	14.84 V
+	18	Statistics	Analog	Clean Isc	0.00m	0.0 ° (N)	6.0605	0	A	1 A
+	19	Statistics	Analog	Clean Voc	0.00m	0.0 ° (N)	101	0	V	14.76 V

SymPRO - 12V Analog - Ch16 – 19

Analog (P-SCM)										
+	20	Statistics	Analog	Soil Isc	0.00m	0.0 ° (N)	6.0605	0	A	1.02 A
+	21	Statistics	Analog	Soil Voc	0.00m	0.0 ° (N)	101	0	V	14.76 V
+	22	Statistics	Analog	Clean Isc	0.00m	0.0 ° (N)	6.0605	0	A	0.99 A
+	23	Statistics	Analog	Clean Voc	0.00m	0.0 ° (N)	101	0	V	14.73 V

SymPRO - P-SCM 9132 - Ch20 – 23

OPERATION OF THE SYSTEM

Cleaning the “Clean” panel

- The clean panel should be regularly cleaned thoroughly with deionized water and a soft, non-abrasive cloth (about once a week or as recommended by your analyst). Deionized water is free from calcium and salt so it will not leave deposits on your PV panels.
- Certain sites may have very abrasive mineral deposits, so be mindful of abrasion when cleaning the PV panels.
- Rainfall also has a natural cleaning effect and should also be recorded at the site with an instrument such as a tipping bucket rain gauge connected to the same data logger.



Sensors | Pulsed Soiling Module (PSM1)

Data Processing – Soiling Calculation

- The measured values (Temp CLEAN, Isc CLEAN, Temp SOILED, Isc SOILED) can be used to determine a Soiling Ratio which compares the soiled PV output to the clean PV output. By monitoring the soiling ratio over time and using additional analysis techniques, the potential impact of soiling losses on a PV farm's energy production can be characterized.
- If using the PSM1 with a SymphoniePRO, the calculation of the soiling ratio must be done in post-processing. Please reference IEC 61724-1 Annex C, method 2 for more information about how to proceed with the collected soiling data.
- For more information about how NRG calculates Effective Irradiance Clean (ch209), Soiling Ratio Isc Index (ch210), and Daily Soiling Ratio (ch211) in the LOGR-S, please refer to "Accurately Measuring PV Soiling Losses with Soiling Station Employing Module Power Measurements".¹ If you are unsure how to process the data, please consult with your analyst, as there are various ways to handle the data. See IEC 61724-1 Annex C, method 2.

MAINTENANCE AND SERVICE

PSM1 Maintenance

The PSM1 should not require maintenance and there are no serviceable parts in the 18872/18860 PSM1. Should an issue occur, contact NRG Technical Services at support@nrgsystems.com.

⚠ WARNING: Should any part of the system need to be returned or replaced, ensure the **18623 Solar Disconnect** is turned to **OFF** prior to any additional work.

⚠ WARNING: Replace the 18890 Solar Disconnect unit with the NRG 18890 Solar Disconnect unit.

TECHNICAL SPECIFICATIONS

Absolute Maximum Ratings ^{1,2}				
	PSM1 (30W)	PSM1 (Crystalline)	PSM1 (Thin Film)	Unit
Supply Voltage	28			V
Supply Voltage Fluctuation ³	±10			%
Supply Current	20			mA
Temperature	-40 to 65			°C

¹ M. Gostein, T. Düster and C. Thuman, "Accurately measuring PV soiling losses with soiling station employing module power measurements," 2015 IEEE 42nd Photovoltaic Specialist Conference (PVSC), New Orleans, LA, USA, 2015, pp. 1-4, doi: 10.1109/PVSC.2015.7355993.



Sensors | Pulsed Soiling Module (PSM1)

PV Input Voltage ²	0 to 450			V
PV Input Current ²	0 to 30	0 to 30	0 to 4	A
Clean VOC Out	0 to 5			V
Clean ISC Out	0 to 5			V
Soiled VOC Out	0 to 5			V
Soiled ISC Out	0 to 5			V
Recommended Operating Conditions				
Supply Voltage	12			V
PV Input Voltage	15 to 25	15 to 65	100 to 450	V
PV Input Current	0.5 to 3	10 to 30	1 to 4	A
Typical Output at Recommended Conditions				
Clean/Soiled VOC Out	0.145 to 0.244	0.145 to 0.638	0.982 to 4.440	V
Clean/Soiled ISC Out	0.083 to 0.494	1.647 to 4.953	0.165 to 0.659	V
Accuracy Specifications (k=2) at Recommended Conditions				
Clean/Soiled VOC Slope	101.5805887	101.4066317	101.2142007	V/V
Clean/Soiled VOC Intercept	0.22330546	0.2561298	0.5650241	V
Clean/Soiled ISC Slope	6.0778972	6.0502922	6.0692799	A/V
Clean/Soiled ISC Intercept	-0.0021218	0.0352457	0.0012959	A
Clean VOC Out	±1			%
Clean ISC Out	±1			%
Soiled VOC Out	±1			%
Soiled ISC Out	±1			%



Sensors | Pulsed Soiling Module (PSM1)

Environmental Conditions		
Altitude ⁴	2000	m
Temperature	-40 to 65	°C
Relative Humidity	0 to 100	%
Ingress Protection Code	IP 65	
Pollution Degree	1	

1: Exceeding Absolute Maximum Ratings, even at short durations risks permanently damaging the product and may expose the operator to bodily harm

2: Operator must verify PV modules do not exceed equipment ratings under any operating conditions. PV modules Open Circuit Voltage and Short Circuit Current are normally specified at Standard Operating Conditions (STC) (1000 W/m², 25 °C). Absolute maximum Open Circuit Voltage and Short Circuit Current must be determined for operation outside STC and verified against products Absolute Maximum Ratings. Contact NRG Systems for more information and/or assistance.

3: Fluctuations (noise / ripple) on the power supply may reduce system accuracy

4: Product may be operated at higher altitudes with reduced ratings. Contact NRG Systems for more information.

Product is designed for outdoor use and in wet locations.



CONTACT INFORMATION

To return a defective product, request an RMA (return merchandise authorization) number by calling us at the number below or by emailing support@nrgsystems.com, or by submitting a request through our website's Technical Support area.

Please provide the serial number of the item as well as date of purchase. No products will be accepted for repair work without an RMA number. The product must be returned, postage prepaid, to NRG with a brief description of the problem, RMA number and a return address with phone number.

For complete information about returns and the RMA process, visit the Return Authorization Request page on our website, located in the Customer Support section.

NRG Systems
110 Riggs Road
Hinesburg, VT 05461, USA
802-482-2255 | nrgsystems.com