

HUKSEFLUX SR30 PYRANOMETER

TECHNICAL PRODUCT SHEET



Overview

The SR30 from Hukseflux provides class A (secondary standard) performance per ISO 9060:2018 along with a rich set of features that are unmatched by other sensors. The all-digital sensor provides high-accuracy irradiance measurements with high data availability due to its integrated heating and ventilation functionality. Unlike traditional, externally heated and ventilated pyranometers, the SR30's internal heating and ventilation system consumes relatively little power and still delivers high data availability.

Specifications

Measurement Range	-400 to 4000 W/m ²
Signal Type	Two Wire Half Duplex MODBUS RS-485
Sensor Accuracy	Class A (secondary standard) ISO 9060:2018 & IEC 61724-1:2017 compliant
Voltage Supply	8 to 30 VDC (standard power mode)
Supply Current	0.25 to 0.375 A (with heater active)
Operating Temperature Range	-40 to 80 C
Sensor Cables	5m, 10m, 20m, and 50m options
Mounting	Met Mast and array mount options available

Please note that as with all thermopile pyranometers, regularly scheduled maintenance is imperative to achieve the sensor's specified performance.

Tools Required

- 3mm Slotted Screwdriver
- 4mm Hex Key



NRGSystems®

Array Mounted Installation:

1. Install the mounting bracket on the array (this example shows mounting bracket #16073) following the applicable instructions.
2. Remove the Sun Screen (white cover) from the pyranometer. Remove the sensor leveling feet and place the sensor on the mounting plate, making sure the cable exits towards the nearest pole (north in the northern hemisphere, south in the southern hemisphere).
3. Thread the two mounting screws into the base of the sensor and tighten until snug (do not over tighten).
4. Attach the sensor cable and place the Sun Screen back on the sensor body.
5. Route the cable to the Power Supply and connect the sensor wires to a power source and RS485 COM Port.

When installing the sensor facing down to collect reflected global irradiance (RPOA), remove the white sun shield and if available use a glare screen.

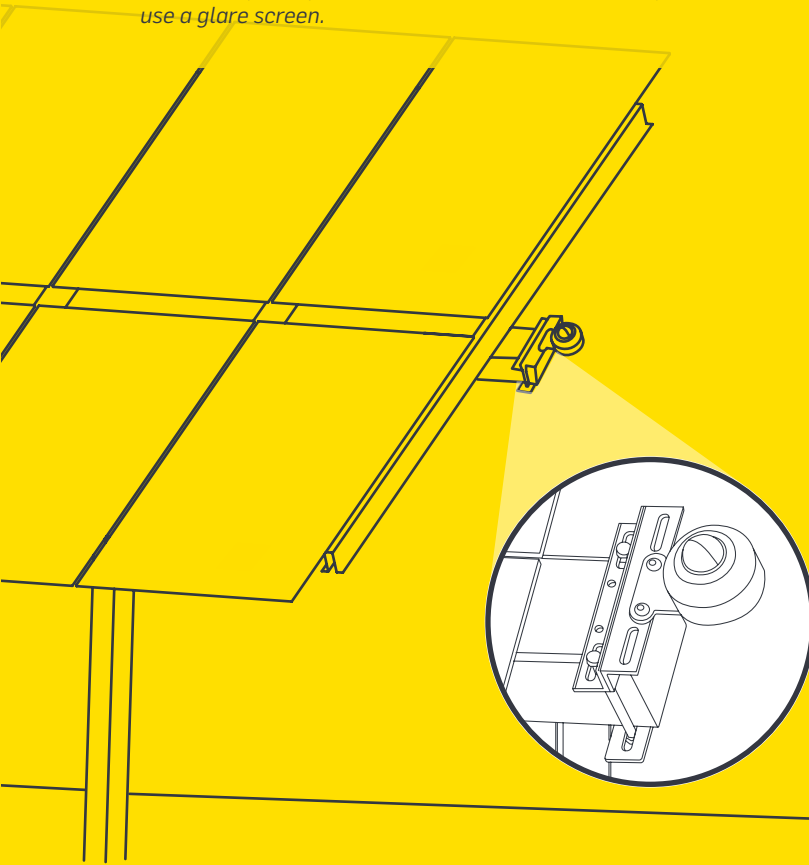

Boom Mounted Installation:

1. Install the Mounting Boom being utilized by following the associated instruction sheet.
2. Assemble and install the pyranometer mounting plate on one end of the mounting boom. Use a level to verify that the mounting plate is level.
3. Remove the Sun Screen (white cover) from the pyranometer. Place the sensor on the mounting plate, making sure the cable exits towards the nearest pole (north in the northern hemisphere, south in the southern hemisphere).
4. Thread the two mounting screws loosely into the base of the sensor. Use the adjustable feet and leveling bubble on the sensor body to level it.
5. Attach the sensor cable and place the Sun Screen back on the sensor body.
6. Route the cable to the Power Supply and connect the sensor wires to a power source and RS485 COM Port.

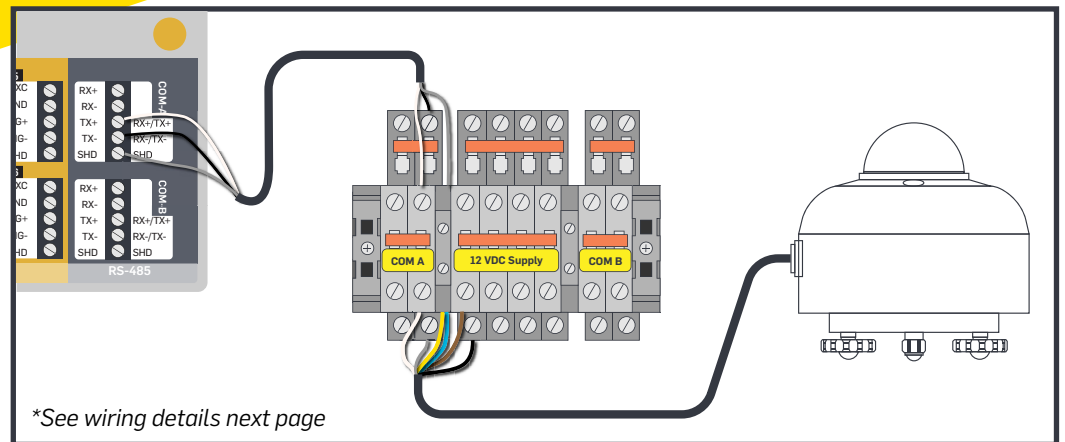
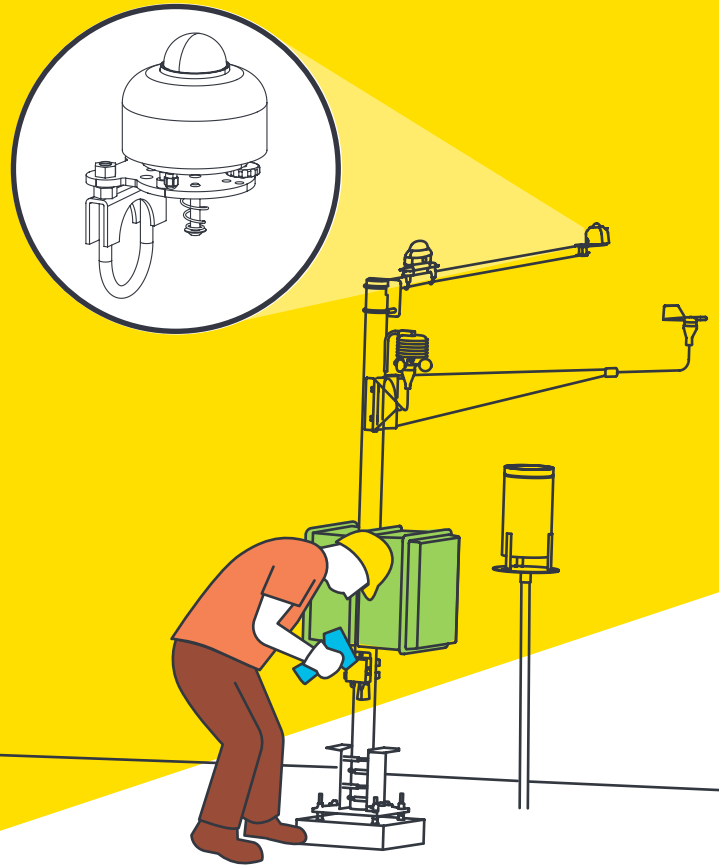

**See wiring details next page*

SymphoniePRO Logger Programming

The Hukseflux SR30-M2-D1 is a digital sensor that utilizes the SymphoniePRO data logger's RS485 COM A and COM B ports.

Once wired into the appropriate COM port (in this example COM A), program the data logger as follows:

(Example on channel 27)

1. Press the + next to the first Serial channel the sensor is being programmed into (27-50)
2. Select the COM port that the sensor is wired into (either A or B)
3. Enter the sensors Slave ID of the sensor. SR30-M2-D1 sensors are typically programmed with Slave ID 1 but if more then two sensors are placed on the same COM port, they must each have unique IDs.
4. Choose "SR30 Pyranometer" as the Device being used
5. Choose the Measurand that will be measured on this channel. Typically the first measurand for the SR30 is "Irradiance".
6. To program additional Measurands, expand the next available channel by pressing the + and follow steps 2 through 5 and choose the next desired measurand.
7. Repeat these steps until all desired measurands are activated.
8. Press "Save All" to save the settings to the logger.

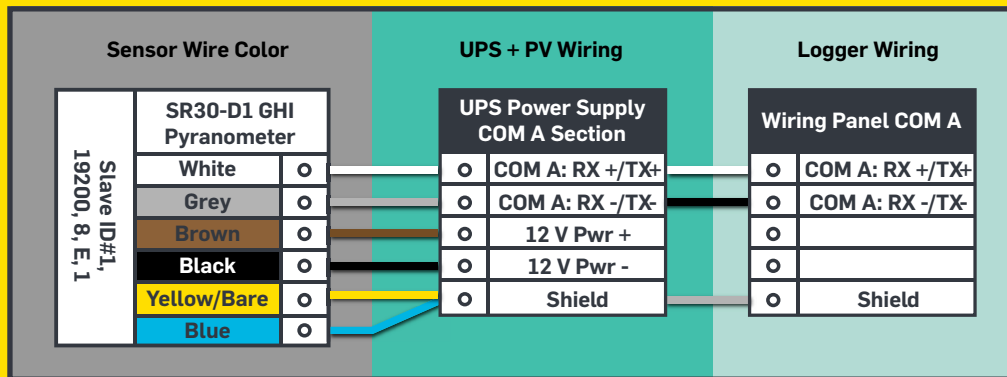

For more information:

NRG Technical Support
 +1 802.482.2255
support@nrgsystems.com
nrgsystems.com
 ISO 9001: 2015 Certified
 ISO 14001: 2015 Self-Certified