

NRG 200M Wind Vane

Authors:

Technical Services





CONTENTS

INTRODUCTION 3

SENSOR IDENTIFICATION 3

POWER REQUIREMENTS..... 3

MOUNTING 4

 Install the sensor onto mounting boom: 4

Note about new NRG mounting boom extension 4

SYMPHONIEPRO 5

 Compatibility 5

 Wiring 5

 Channel Configuration 6

Default Scale Factors (Desktop Application 3.2.X and later)..... 6

Boom Bearing and Vane Mounting Angle..... 7

Built in Channels 13-15 7

P-SCM Channels 20-26 8

SYMPHONIEPLUS3..... 9

 Wiring 9

Channels 7 and 8 9

Flex Channels 4-6 and Analog channels 9-12..... 9

 Channel Configuration 10

Determining Offset Value 11

SPECIFICATIONS..... 12



INTRODUCTION

The NRG 200M Wind Vane (introduced January, 2018) has the same form factor as the NRG 200P, and utilizes a new signal transducer which eliminates the dead band and lowers uncertainty. Additionally, sensors are individually serialized, and compatible with NRG SymphoniePRO and SymphoniePLUS3 loggers. For quality traceability, a manufacturing calibration report is available for each individual sensor.

For reliable results while using pulsed excitation on **third party data loggers**, configure the logger to record samples 150ms after excitation. If the logger does not support this configuration then revert to constant excitation.

SENSOR IDENTIFICATION

The 200M can be identified by the yellow label on the base of the body, which contains the “NRG 200M” model name, serial number (10070-NNNNNNNN), wiring information (“-”, “Signal”, “+”), and barcode.

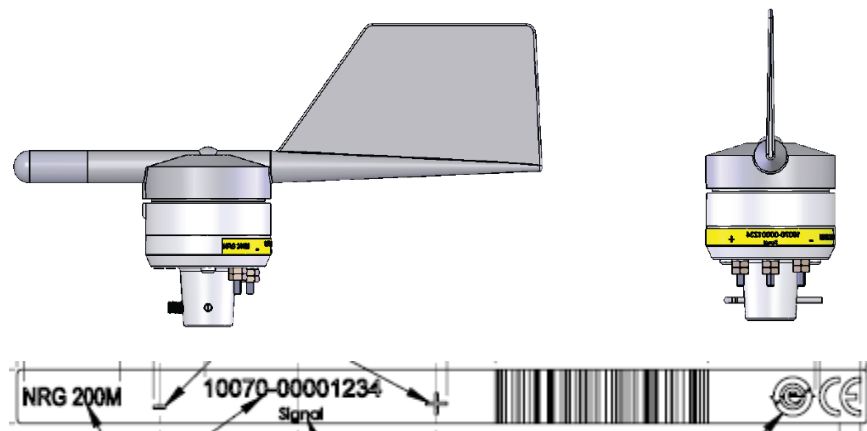

POWER REQUIREMENTS

The 200M vane requires an excitation voltage of (4.5 to 15) V and consumes 1.5 mA of current. The terminals of the 200M are the same as the 200P, but due to the different power requirements care must be taken when connecting to a SymphoniePLUS3 logger. The EXC terminals found on the SymphoniePLUS3 vane channels 7, 8, vane SCM do not provide enough energy to power the 200M.

Logger	2.5V Pulsed EXC	5V Pulsed EXC	5V Constant EXC	12V Constant EXC
NRG SymphoniePLUS3	<i>Do not use*</i>	<i>Do not use*</i>	N/A*	18 mW
NRG SymphoniePRO	<i>Do not use*</i>	Default: 5.3 mW	7.5 mW	18 mW

***NOTE: DO NOT use the EXC terminal from a SymphoniePLUS3 logger vane channel 7, 8, or vane SCM when connecting a 200M. DO NOT use 200P sensor configuration settings on SymphoniePRO; if you do not see 200M**



in the sensor drop down list please update your Desktop Software and SymphoniePRO logger Firmware. Please review the logger specific wiring information included in this document!

MOUNTING

The 200M utilizes a new mounting screw arrangement which achieves superior sensor to boom alignment over the previous (200P) design. The mounting process is virtually identical to the 200P.

Install the sensor onto mounting boom:

1. Place the flexible black sensor boot onto the boom.
2. Feed the sensor signal cable up through the boot.
3. Slide the 200M onto the boom such that the set screw of the vane aligns with the flat on the sensor mounting boom. If the boom does not have a flat, position the sensor in the desired orientation.
4. Install and secure the cotter pin.
5. Tighten the sensor set screw using a #1 Philips (+) screw driver.
6. Make your sensor to cable connections as follows (use a ¼ inch nut driver to tighten the nuts)
 - a. (-) to black wire
 - b. (signal) to clear wire
 - c. (+) to red wire
7. Slide the boot up onto the sensor body.

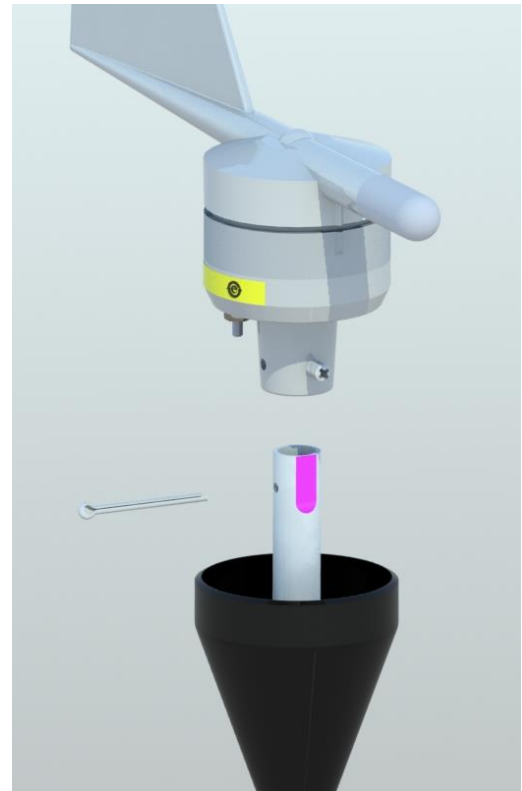

Note about new NRG mounting boom extension

As of January 2018, standard NRG mounting boom sensor extensions* have been updated to provide a small flat surface for the set screw to land on. This ensures the 200M vane north mark is oriented directly in line with the side mount boom arm pointing at the tower.

***Booms updated for improved 200M Mounting (January 2018)**

NRG Mounting Boom Item	Description	Compatibility
4159	Mounting Boom 2.4m (95"), Tubular (2)	NRG 200P and 200M Vanes, NRG 40C Anemometer NRG Class 1 Anemometer
4214	Mounting Boom 2.4m (95"), Tubular (1)	NRG 200P and 200M Vanes, NRG 40C Anemometer NRG Class 1 Anemometer
9342	Boom Extension for 40C, 200P, NRG Class 1, 200M, 26.7D	NRG 200P and 200M Vanes NRG 40C Anemometer NRG Class 1 Anemometer

If using a boom with an older design for the 200P vane, the 200M can be mounted in the same way as a 200P without any modification. A table of boom item numbers has been included for convenience.



SYMPHONIEPRO

Compatibility

The NRG 200M Wind Vane is compatible with SymphoniePRO Desktop Application 3.2.X and later (3.5.1 and later recommended); and logger firmware 2.3.1 and later.

NOTE: Please update your desktop software and logger firmware before performing logger configuration and/or data processing tasks. The latest versions of software, firmware and documentation can be downloaded from this page: <https://www.nrgsystems.com/services-support/resources/documentation-and-downloads/>.

Wiring

Wiring the NRG 200M to the SymphoniePRO is straight forward and familiar. Please follow the tables below.

Built in Channels 13-15

Channels 13 - 15 (no SCM required)		
200M Connection	Color	SymphoniePRO Logger
+	Red	Connect to 13-15 "EXC" terminal
Signal	Clear	Connect to 13-15 "SIG" terminal
-	Black	Connect to 13-15 "GND" terminal

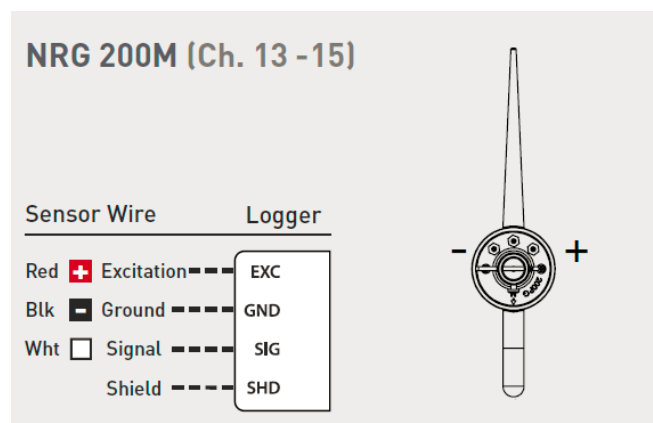



Sensors | 200M Wind Vane

P-SCM Channels 20-26

<i>Channels 20-26 (use P-SCM #9130)</i>		
200M Connection	Color	SymphoniePRO Logger
+	Red	Connect to 20-26 "EXC" terminal
Signal	Clear	Connect to 20-26 "SIG" terminal
-	Black	Connect to 20-26 "GND" terminal

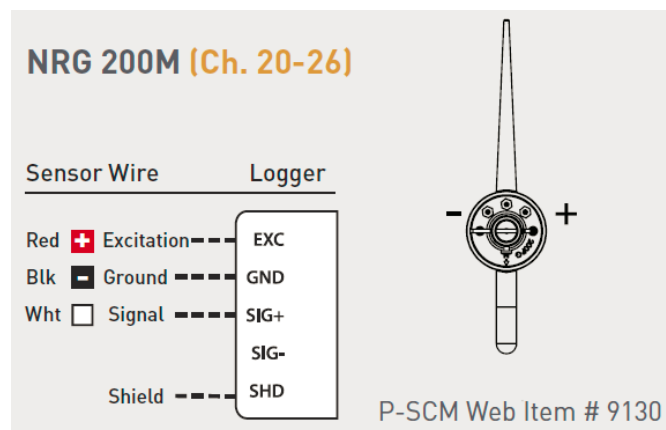

Channel Configuration

Create the following configuration in the SymphoniePRO Desktop Application (Version 3.2.X or later). Note, if you do not see the 200M in the "Load From Defaults" drop-down menu, please update your software from the "Services and Support" section of our website (<https://www.nrgsystems.com>).

Default Scale Factors (Desktop Application 3.2.X and later)

The SymphoniePRO Desktop Application contains default scaling information for the 200M wind vane. It is also possible to configure using other scaling information such as from an individual sensor's calibration report.

- Scale Factor: 147.91
- Offset: -1.460



Boom Bearing and Vane Mounting Angle

SymphoniePRO has configuration fields not found in previous NRG loggers such as the SymphoniePLUS3. The **Boom Bearing** field indicates the sensor boom orientation in positive degrees relative to north. This field can also be used to factor in the magnetic declination (site specific variation between magnetic north and true north:

<http://www.ngdc.noaa.gov/geomag-web/>).

In addition to the Boom Bearing field, there is the option to enter a **Vane Mounting Angle** for wind vane channels. Vane Mounting Angle defines the angle of the “North Mark” on the vane relative to the boom. Zero degrees indicates the mark is facing away from the boom and tower; 180 degrees indicates that the mark is directly facing the boom and the tower.

An explanation of the Boom Bearing and Vane Mounting Angle is available by hovering over the Vane Mounting Angle tooltip in SymphoniePRO Desktop Application.

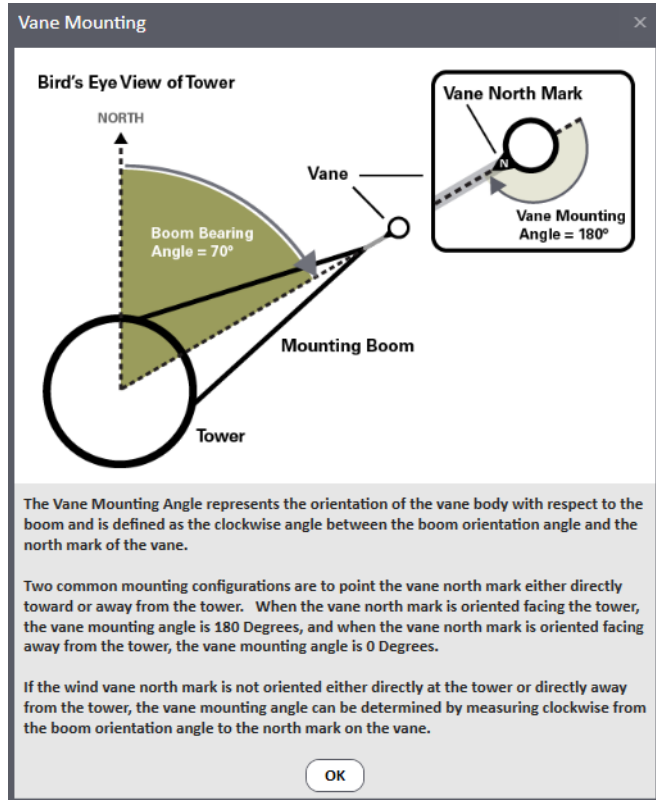

Built in Channels 13-15

The 200M can be installed on logger channels 13-15 without the need for a P-SCM. Choose “NRG 200M Wind Vane” from the “Load From Defaults” drop down menu.

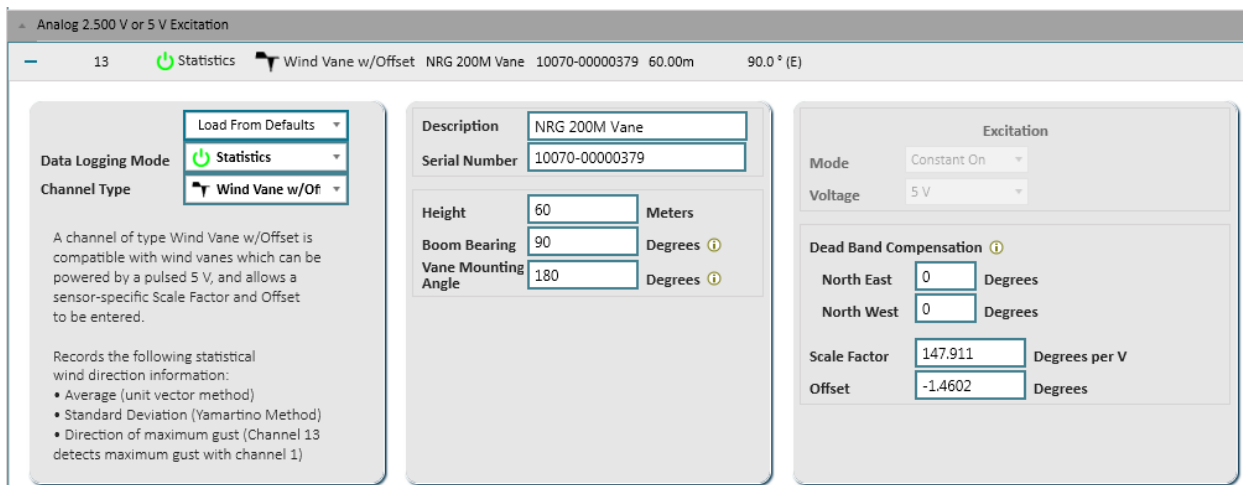



P-SCM Channels 20-26

The 200M vane can be used on channels 20-26 when the logger is equipped with one of the P-SCM cards listed below.

Part Number	Input Type	Excitation Voltage
9130	0-5V SE Input	5V Pulsed
9131	0-5V SE Input	12V Pulsed
9132	0-5V SE Input	12V Constant
9410	0-5V SE Input	5V Constant

The recommended P-SCM card (and the default in channels 20-26) is #9130, because it results in the lowest power consumption by the logger.



SYMPHONIEPLUS3

Wiring

Channels 7 and 8

- Signal and GND are wired as normal, connect to analog channel 7 or 8.
- EXC can be connected from digital-counter channels 1-3, or 13-15 (this supplies constant 12 V to the 200M)

NOTE: Do NOT connect the EXC to channel 7 or 8!

Channels 7 and 8 (no SCM required)		
200M Connection	Color	SymphoniePLUS3 Logger
+	Red	Connect to channel 1-3, 13-15 "EXC" terminal
Signal	Clear	Connect to channel 7-8 "SIG" terminal
-	Black	Connect to channel 7-8 "GND" terminal

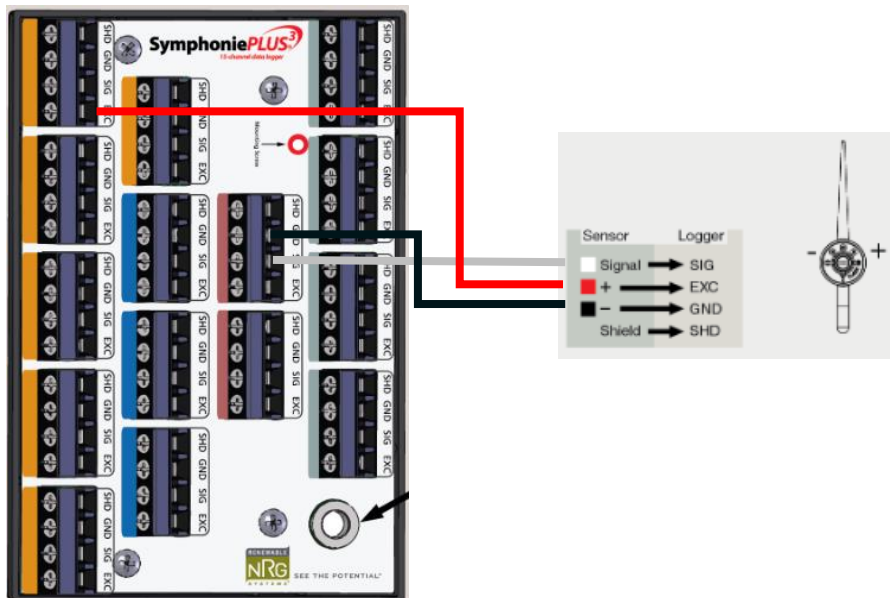

Flex Channels 4-6 and Analog channels 9-12

Signal and GND are wired into a channel with wind vane SCM (#3152) present; either a flex channel 4-6, or an analog channel 9-12.



Sensors | 200M Wind Vane

- Signal and GND are wired as normal, connect to analog channel 7 or 8
- EXC can be connected from digital-counter channels 1-3, or 13-15 (this supplies constant 12 V to the 200M)

NOTE: Do NOT connect the EXC to channel 7 or 8!

Channels 4-6, 9-12 (requires SCM 3152)		
200M Connection	Color	SymphoniePLUS3 Logger
+	Red	Connect to channel 1-3, 13-15 "EXC" terminal
Signal	Clear	Connect to channel 4-6, 9-12 "SIG" terminal
-	Black	Connect to channel 4-6, 9-12 "GND" terminal

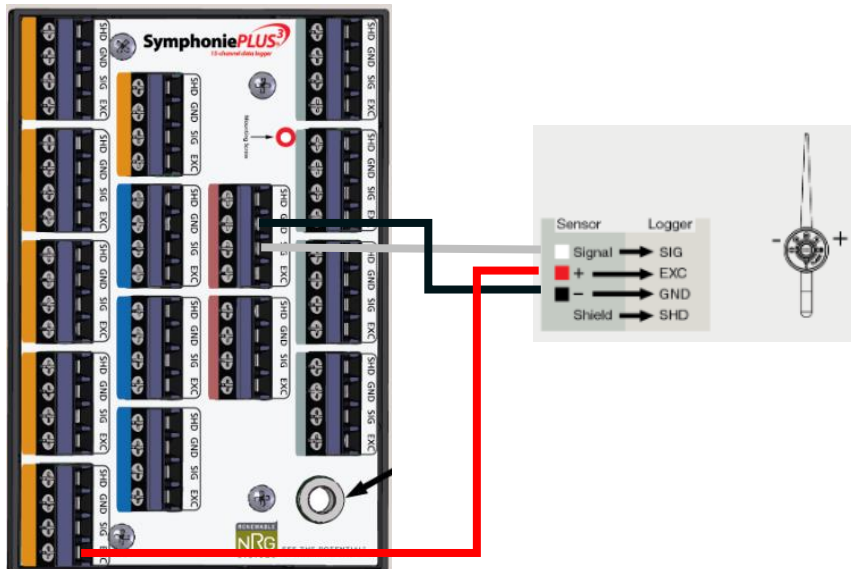

Channel Configuration

The 200M has a different default scaling than the 200P. *Do not use the 200P settings found in SDR!*

Instead, configure as follows:

- Slope: 0.368
- Offset: -5.3 (see section below about integrating boom direction into offset)



Site Information		Sensor Information	
Site #	2222	Channel #	7
Site Desc	Windy Meadows	As of	Baseline
Project Code	MVT1	Description	NRG 200M Wind Vane
Project Desc	Late Stage Prospecting	Details	boom pointing north (0 Deg)
Site Location	Meadowville, VT	Serial Number	00000768
Site Elevation	300	Height	60 m
Base Time Zone	(UTC-05:00) Indiana (East)	Scale Factor	0.368
Latitude	44.3292 N	Offset	-5.3
Longitude	73.1107 W	Print Precision	0
Serial Number (5-digit suffix)	12222	Units	deg
Hardware Rev.	009-009-014	Notes	
Encryption Code:	0000	History	Delete
		Make New Change	

Determining Offset Value

North Mark Pointing Away from Tower

If the boom heading is pointing in a direction other than North (0 degrees) and the north mark of the 200M is facing away from the tower, calculate your overall offset as follows:

- **Offset = Boom Heading – 5.3**
 - **Example:** Boom Heading is 90 Deg (East) and the North Mark on the vane is pointing away from the tower.
 - Offset = 90 – 5.3
= 84.7

North Mark Pointing Toward Tower

If the boom heading is pointing in a direction other than North (0 degrees) and the north mark of the 200M is facing toward the tower, calculate your overall offset this way:

- **Offset = Boom Heading + 180 - 5.3**
 - **Example:** Boom Heading is 90 Degrees (East) and the North Mark on the vane is pointing toward the tower.
 - Offset = 180 + 90 – 5.3
= 264.7



SPECIFICATIONS

Please see nrgsystems.com for up to date product specifications.

Description	Sensor type	Continuous rotation wind direction vane
	Applications	Wind resource assessment Meteorological studies Environmental monitoring
	Sensor range	360° mechanical, continuous rotation
	Instrument compatibility	All Symphonie Data Loggers
	Measurement range	0 - 360°
Output signal	Signal type	Analog DC voltage
	Linearity	0.1°
	Transfer function	<p>SymphoniePRO*:</p> <p>Default slope = 147.91°/V</p> <p>Default offset = -1.460°</p> <p>SymphoniePLUS3*:</p> <p>Default slope = 0.368°/V</p> <p>Default offset = -5.3°</p> <p>Individual sensor transfer function is available via factory calibration certificate.</p>
	Dead band	None



	Calibration	Each sensor is individually factory calibrated. Factory calibration certificates provided via electronic download.
	Output signal range	0.007Vdc to 2.5Vdc
	Uncertainty	Expanded uncertainty (k=2) 95% confidence [Sensor only]: +/-1.6° (>0.9° to <359.1°) +/-2.5° (359.1° to 0.9°)
Response characteristics	Threshold	1.5 m/s (3.35 mph) @+/-10°, 0.97 m/s (2.16 mph) @+/-90° per ASTM D5366-96
	Delay distance	1.18 m (@5 m/s), 1.20 (@10 m/s) per ASTM D5366-96
Power requirements	Supply voltage	4.5 Vdc to 15 Vdc
	Supply current	1.5mA
Installation	Mounting	Onto a 13 mm (0.5") diameter mast with cotter pin and #2 phillips set screw. *Note: Use of NRG boom extension with alignment feature provides standardized set screw landing location and sensor orientation.
	Tools required	#1-Phillips driver, 0.25" nut driver, petroleum jelly, electrical tape
Environmental	Operating temperature range	-40°C to 60°C (-40°F to 140°F)
	Operating humidity range	0 to 100% RH
Physical	Connections	4-40 nickel plated brass hex nut/post terminals
	Weight	0.108 kg (0.238 pounds)



	Dimensions	21 cm (8.3 inches) length x 12 cm (4.3 inches) height 27 cm (10.5 inches) swept diameter
Materials	Wing	Black UV stabilized injection-molded plastic
	Body	Black UV stabilized static-dissipating plastic
	Shaft	Stainless steel
	Bearing	Stainless steel
	Magnet	Neodymium
	Boot	Protective PVC sensor terminal boot included
	Terminals	Nickel plated brass